



Wabtec
CORPORATION



MARINE FENDERS

PROTECTION, DURABILITY AND ECONOMY
FOR TRUE DESIGN FREEDOM

TYPICAL DOCK FENDER INSTALLATIONS



Precurved Rectangular Tug Boat Bow Fenders



**15" OD X 7-1/2" ID Cylindricals
U.S. Coast Guard Station, St. Petersburg, FL**



**12" x 12" Rectangulars
U.S. Coast Guard Station, Miami, FL**



**24" OD X 12" ID Cylindrical (End Loaded)
Port of Houston, Houston, TX**

TABLE OF CONTENTS

Longwood Marine Fenders—Introduction	Page 3
Fender Selection	Page 4
Rubber Compounds and Specifications	Page 5
Standard Cylindrical Fenders: Sizes, Load-Deflection and Energy-Deflection Curves Mounting Hardware	Pages 6—7 Pages 8—9
Rectangular Fenders: Sizes, Load-Deflection and Energy-Deflection Curves Mounting Hardware	Pages 10—11 Pages 12—13
D-Shaped Fenders – O Bore, and D Bore: Sizes Load-Deflection and Energy-Deflection Curves Mounting Hardware	Page 14 Page 15 Pages 16—17
Wing Type Fenders: Sizes Load-Deflection and Energy-Deflection Curves Mounting Hardware	Page 18 Page 19 Pages 20
Trapezoidal Fenders – R Series, and W Series: Sizes Load-Deflection and Energy-Deflection Curves Mounting Hardware	Page 21 Page 22 Pages 23—24
V-Series – Arch Fenders: Sizes Load-Deflection and Energy-Deflection Curves Mounting Hardware	Page 25 Page 26 Pages 27
M-Series Fenders: Sizes Load-Deflection and Energy-Deflection Curves Mounting Hardware	Page 28 Page 29 Pages 30
End-Loaded Cylindrical Fenders: Sizes Load-Deflection and Energy-Deflection Curves	Page 31 Page 32
Miscellaneous Fenders: Edge Guard, and Boat Rail Guard	Page 33
Double Bore Ship Fender	Page 34
Typical Y.T.B. Tug Boat Fender Installations	Pages 35

LONGWOOD MARINE FENDERS

The first rubber marine fenders were developed and installed by Goodyear in 1933 and introduced a new era of design freedom for the marine architect.

They quickly established a solid reputation for reliable protection, durability and economy in rough usage and over a wide variety of climatic and tidal conditions.

In January of 1998, Longwood Elastomers, Inc. purchased this marine fender business from Goodyear. Longwood Elastomers, Inc. is a subsidiary of Longwood Industries, Inc. We have been producing specialized rubber products for more than 100 years and are committed to providing quality products and quality customer service.

Longwood marine fenders are found in applications ranging from piers, docks, dolphins and other harbor structures, to tugs, barges, ferries and similar hard working vessels subject to frequent and severe impact.

Effective Absorption of High Energy Impacts

Rubber fenders readily absorb the high energy impacts inherent in the berthing, mooring and pushing that marine structures and vessels encounter every day. Under the severe loads that cause other materials to crush, splinter or buckle, Longwood rubber fenders simply compress, then return to their original shape. This resiliency preserves the fenders, the structure and the vessel to eliminate replacement expense and out-of-service conditions.

Low Cost Installation and Maintenance

In many cases, the original cost of Longwood marine fenders is lower than the cost of less effective protective material. But that's just the beginning of the real economy they offer. Even bigger savings are achieved through lower maintenance costs due to the long-lived properties of the specially compounded rubber

used for Longwood marine fenders.

For example, rubber is resistant to the contaminants and effluents frequently found in industrialized rivers and harbors. And it resists the cutting, gouging, and abrasion which destroy other materials.

Rubber is not subject to fungoid growth which causes the decay of wooden or rope fenders. And it is practically immune to marine growth, termites, borers and other insects.

Environmentally Tailored Compounds

Longwood marine fenders are available in a range of rubber compounds to meet the most demanding service conditions. A variety of property profiles have been developed to provide increased resistance to oil, chemicals, weather, ozone, severe loads, grinding impacts and temperature extremes.

All are designed to provide an excellent combination of tensile strength, resilience and energy absorption.

Load-Energy Curves

Load-Deflection and Energy-Deflection curves are shown on the following pages.

The scale of the charts has been changed to make the curves easier to read in the normal working range of the fenders. For this reason, we did not extend the graphs to show the maximum loads the fenders are capable of withstanding. Information regarding the maximum recommended capacities of the fenders is available upon request.

In making a comparison with other published curves, it is important that the engineer recognize the curves are dependent on test methods. When testing using the same conditions, fenders show equivalent load-deflection and energy-deflection characteristics. Test procedure information is available upon request.

Contact your local Longwood Marine Fender distributor for more engineering data and design information.

Call 1-800-888-9703, extension #130

for the distributor in your area.

NOTE:

Standard tolerances are $\pm 4\%$ on exterior dimensions, $\pm 8\%$ on interior dimensions, and the greater of $\pm 2\%$ or $\pm 1"$ on length. Contact the factory if closer tolerances are required.

FENDER SELECTION

There are many service factors which must be considered when making a decision on which type and size of fender is best for a given application. These include:

- The type of pier structure.
- The type and size of the vessel it will handle.
- The berthing velocity of the vessels.
- The method of berthing.
- The sea currents and wave actions involved.

The information below is provided as an outline of the most common applications of the various Longwood rubber fender profiles. A digest of pertinent engineering, performance and design data for each profile is provided in later sections of this brochure.



**CYLINDRICAL
FENDERS**

Cylindrical fenders are normally used where tidal conditions exist and flexible mounting is desired. They are usually suspended on a chain or festooned for easy installation. (See pages 6-9 for additional information.) (See pages 31 and 32 for end-loaded information.)

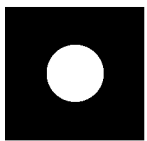

**RECTANGULAR
FENDERS**

Rectangular fenders are normally used where rigid mounting is desired. They are widely used on tugs, and on harbor structures where tidal conditions do not exist and where berthing is at a low angle. Rectangular fenders are also used in combination with wood facings on light concrete structures where the load imparted to the dock structure must be kept low. The wood facing spreads the berthing impact over a larger surface area to avoid concentrated loads on any one point. (See pages 10-13 for additional information.)



**D-SHAPED
AND WING-TYPE FENDERS**

D-Shaped and Wing-Type fenders offer the high energy absorption required for tugs, barges and other service vessels. Their cross sections are designed for solid mounting and complete coverage. (See pages 14-20 for additional information.)



**TRAPEZOIDAL
FENDERS**



Trapezoidal fenders are used with or without timber facing where the dock structure or the vessel is unable to withstand large reaction loads. Longwood's trapezoidal design is engineered to use rubber's natural elasticity more efficiently. Thus, a smaller section will absorb a greater impact when compared to other cross sections. (See pages 21-24 for additional information.)



V-SERIES FENDERS

V-Series fenders are used with timber to achieve the maximum cushioning effect. The timbers serve to distribute the load over a wider area, while the fenders absorb the energy and minimize reaction loads to the structure. (See pages 25-27 for additional information.)



M-SERIES

M-Series fenders offer protection for small vessel dock structures as well as having many industrial uses. They can protect trucks, loading docks and industrial property. They can be easily moved to meet changing conditions. (See pages 28-30 for additional information.)

RUBBER COMPOUNDS AND SPECIFICATIONS

Longwood High Performance Black EPDM Compound

Military Specification MIL-R-3065C, MIL Std 417, Type R, Class RS, Grade 720 A, B, C₁, F₂, Z₁, Z₂, and Z₃

ASTM Designation — D-2000 3BA 720A₁₄, B₁₃, C₁₂, F₁₉, Z₁, Z₂, and Z₃

Longwood Black SBR Compound

Military Specification — MIL-R-3065C, MIL Std 417, Type R, Class RS, Grade 720 A, B, C₁, F₁, Z₁, Z₂, and Z₃

ASTM Designation — D-2000 4AA 720 A₁₃, B₁₃, C₁₂, EA₁₄, F₁₇, Z₁, and Z₂

Longwood Non-Marking Gray EPDM Compound

ASTM Designation — D-2000 3BA710A₁₄, C₁₂, F₁₉, Z₁, Z₂, Z₃, and Z₄

PROPERTY	TEST METHOD	BLACK EPDM	BLACK SBR	GRAY EPDM
Min. Tensile Strength	ASTM D-412	2000 PSI	2000 PSI	1000 PSI
Min. Elongation	ASTM D-412	300%	300%	200%
Hardness-Shore A Durometer	ASTM D-412	70 ± 5	70 ± 5	70 ± 5
Modulus @ 400% Elongation	ASTM D-412	900 PSI Min.	900 PSI Min.	300 PSI Min.
Heat Resistance	ASTM D-573 A ₁₄ 70 h @ 212°F A ₁₃ 70 h @ 158°F Max. Change in Hardness Max. Change in Tensile Max. Change in Ultimate Elongation	+ 10 Pts. - 25% - 25%	+ 10 Pts. - 25% - 25%	+ 10 Pts. - 25% - 25%
Compression Set	ASTM D-395 Method B B ₁₃ & Z ₄ 22 h @ 158°F	25% Max.	25% Max.	50% Max.
Ozone Resistance	ASTM D-1171 C ₁₂ 100°F @ 50 ppm	No Cracks	No Cracks	No Cracks
Water Resistance	ASTM D-471 EA ₁₄ 70 h @ 212°F Z ₃ 166 h @ 212°F	10% Max. Swell	10% Max. Swell	10% Max. Swell
Low Temperature Brittleness	ASTM D-2137 Method A, 9.3.2 F ₁₇ Non-brittle after 3 min. @ - 40°F F ₁₉ Non-brittle after 3 min. @ - 67°F	Passes	Passes	Passes
Load Deflection	ASTM D-575 Method A Z ₁ 20% Deflection	300 ± 70 PSI	300 ± 70 PSI	250 ± 70 PSI
Tear Resistance	ASTM D-624 Z ₂ Die B	200 PPI Min.	200 PPI Min.	150 PPI Min.

STANDARD CYLINDRICAL FENDERS

The inherent lateral flexibility of Cylindrical fenders gives them the widest range of mounting options available. They may be draped, suspended, or strung on chains to provide protection through tidal changes or where substantial vessel draft variations are anticipated. Where straight mounting is desired, a metal bar through the bore will provide the lateral stiffness required. They may also be curved to meet special contours on structures or vessels.

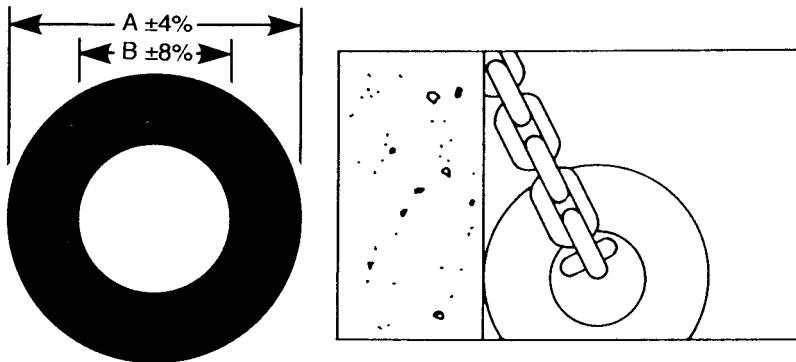

STANDARD CYLINDRICAL							
O.D.	A	MM	I.D.	B	MM	APPROX. LBS./FT.	APPROX. Kg/M
3"	76	1-3/8"	35	3	4		
5"	127	2-1/2"	64	8	11		
7"	178	3"	76	16	24		
7"	178	3-1/2"	89	15	22		
7"	178	5"	127	10	14		
8"	203	3-1/2"	89	21	31		
8"	203	4"	102	19	29		
9"	229	3"	76	29	43		
10"	254	5"	127	30	45		
12"	305	4"	102	51	76		
12"	305	6"	152	43	65		
15"	381	5"	127	80	120		
15"	381	7-1/2"	191	68	101		
18"	457	6"	152	116	172		
18"	457	9"	229	98	145		
21"	533	10-1/2"	267	133	198		
24"	610	12"	305	173	258		
27"	686	13-1/2"	343	220	327		
28"	711	14"	356	236	351		

QUICK REFERENCE CHART

Contact factory if other sizes required.

LOAD — ENERGY VALUES FOR POPULAR CYLINDRICAL FENDERS

L = LOAD IN POUNDS PER FOOT OF FENDER
E = ENERGY IN FOOT-POUNDS PER FOOT OF FENDER

SIZE

SIZE	L	E	1	2	3	4	5	6	7	8	9	10	11	12	13	14	15	16
8 x 4	L		3500	10000	47000													
	E		500	900	3000													
10 x 5	L			4500	13000	70000												
	E			900	1600	5000												
12 x 6	L				6000	22000	70000											
	E				1200	2000	6000											
15 x 7-1/2	L					7000	10000	42000										
	E					1900	2500	4500										
18 x 9	L							8500	17000	45000								
	E							3200	4000	6200								
21 x 10-1/2	L								10000	14000	40000							
	E								3900	5000	6800							
24 x 12	L									4800	15000	28000	70000					
	E									4800	5800	7300	11500					
27 x 13-1/2	L											17000	30000	63000				
	E											7200	9000	12500				

DEFLECTION IN INCHES

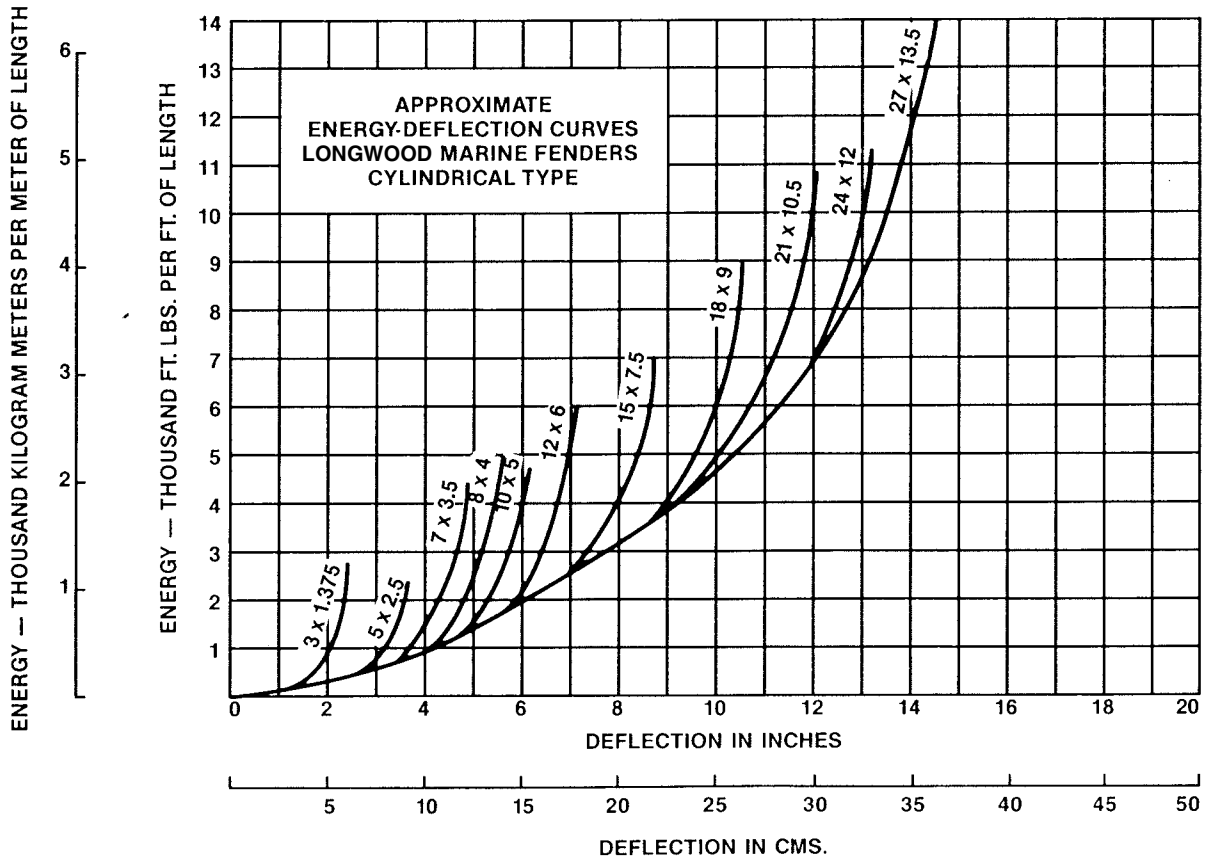
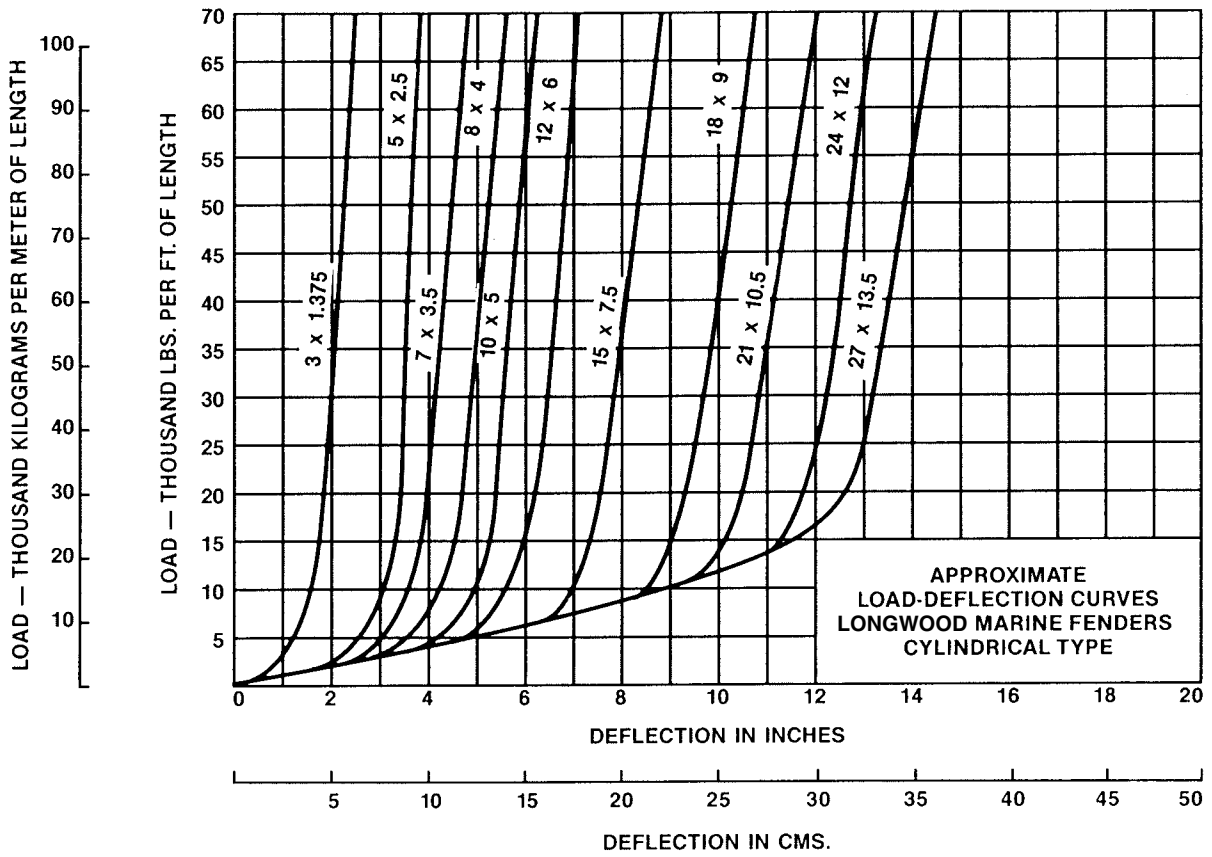

MARINE FENDER HARDWARE

TYPICAL FLEXIBLE MOUNTING OF LONGWOOD FENDERS

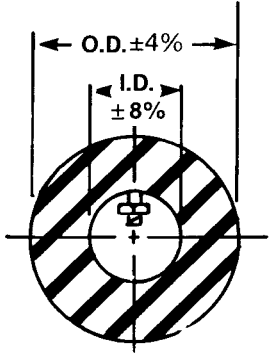
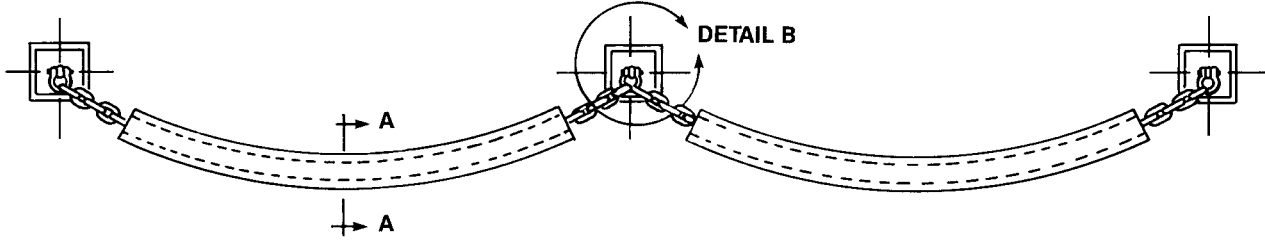

CYLINDRICAL

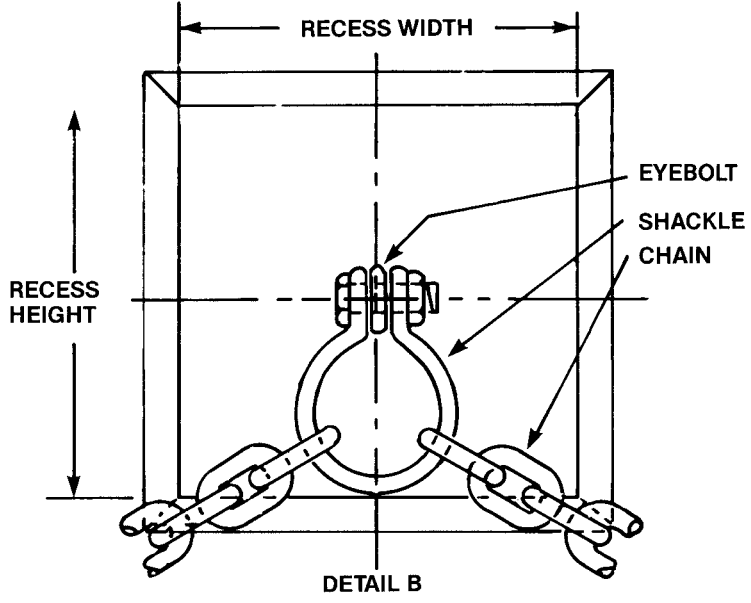

MARINE FENDER HARDWARE FLEXIBLE MOUNTINGS

(ALL DIMENSIONS IN INCHES UNLESS OTHERWISE SPECIFIED)

FENDER SHAPE AND SIZE	WEIGHT POUNDS/FT.	CHAIN		EYEBOLT		RECESS	
		CHAIN SIZE (A)	SHACKLE SIZE (B)	SIZE (STEEL)	SIZE (C) (CONCRETE)	WIDTH & HEIGHT	DEPTH
CYLINDER (OD x ID)							
3" x 1-3/8"	2.7	3/8 DF	1/2	5/8 x L (D)	3/4 x 7	12	3
5" x 2"	8.3	3/8 DF	1/2	3/4 x L	3/4 x 7	14	3
5" x 2-1/2"	7.2	3/8 DF	1/2	3/4 x L	3/4 x 7	14	3
7" x 3"	15.4	1/2 DF	5/8	1 x L	1 x 9-1/2	14	3
7" x 3-1/2"	14.3	1/2 DF	5/8	1 x L	1 x 9-1/2	14	3
7" x 5"	9.3	1/2 DF	5/8	1 x L	1 x 9-1/2	14	3
8" x 3-1/2"	20.1	1/2 DF	5/8	1 x L	1 x 9-1/2	14	3
8" x 4"	18.6	1/2 DF	5/8	1 x L	1 x 9-1/2	14	3
9" x 3"	27.8	5/8 DF	3/4	1-1/4 x L	1-1/4 x 12	16	4
10" x 2"	37.1	5/8 DF	3/4	1-1/4 x L	1-1/4 x 12	16	4
10" x 5"	29.0	5/8 DF	3/4	1-1/4 x L	1-1/4 x 12	16	4
12" x 4"	49.5	5/8 DF	3/4	1-1/4 x L	1-1/4 x 12	16	4
12" x 6"	41.8	5/8 DF	3/4	1-1/4 x L	1-1/4 x 12	16	4
15" x 5"	77.5	5/8 DF	3/4	1-1/4 x L	1-1/4 x 12	18	5
15" x 7-1/2"	65.5	5/8 DF	3/4	1-1/4 x L	1-1/4 x 12	18	5
18" x 9"	94.3	3/4 DF	1	1-1/2 x L	1-1/2 x 14	18	5
21" x 10-1/2"	128.0	3/4 DF	1	1-1/2 x L	1-1/2 x 14	18	5
24" x 12"	167.0	3/4 DF	1	1-1/2 x L	1-1/2 x 14	18	5
27" x 13-1/2"	212.0	1 DF	1-1/4	1-3/4 x L	1-3/4 x 17-1/2	18	5

FOOTNOTES

- (A) GALVANIZED
- (B) SAFETY SHACKLES
- (C) SCREW ANCHOR OR EQUAL
- (D) LENGTH

RECTANGULAR FENDERS

The Rectangular profile is the most rigid of the Longwood rubber fender designs. It may be surface mounted where tidal actions are not a consideration and where berthing angles are low. It may be mounted horizontally or vertically behind timbers to provide extra cushioning where dock loading must be kept low. It can be precurved during extrusion for solid mounting on vessels. This versatility in protecting both structures and vessels is enhanced by a wide range of available sizes.



RECTANGULAR

Height A		Width B		"C" Bore		Weight	
mm	in.	mm	in.	mm	in.	kg/m	lbs./ft.
89	3-1/2"	114	4-1/2"	25	1"	11	8
127	5"	152	6"	64	2-1/2"	19	13
127	5"	165	6-1/2"	64	2-1/2"	21	14
152	6"	254	10"	76	3"	40	27
178	7"	254	10"	76	3"	48	32
203	8"	203	8"	76x76	3"	43	29
203	8"	203	8"	76	3"	43	29
203	8"	254	10"	76	3"	55	37
203	8"	254	10"	76x76	3"	55	37
254	10"	254	10"	102	4"	67	45
254	10"	254	10"	102x102	4"	65	44
254	10"	305	12"	102	4"	82	55
254	10"	305	12"	102x102	4"	80	54
254	10"	305	12"	127	5"	76	51
305	12"	305	12"	102	4"	100	67
305	12"	305	12"	127	5"	95	64
305	12"	305	12"	152x152	6"	85	57
305	12"	305	12"	152	6"	88	59
305	12"	356	14"	152	6"	106	71
356	14"	356	14"	152	6"	128	86
356	14"	356	14"	152x152	6"	125	84
356	14"	356	14"	178x178	7"	116	78
406	16"	406	16"	152	6"	173	116
457	18"	457	18"	254	10"	187	126
508	20"	508	20"	204	8"	266	179

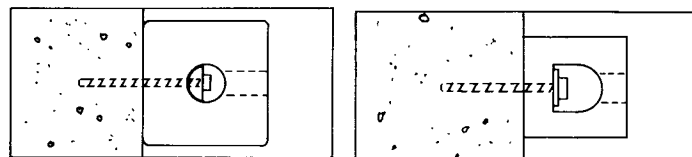
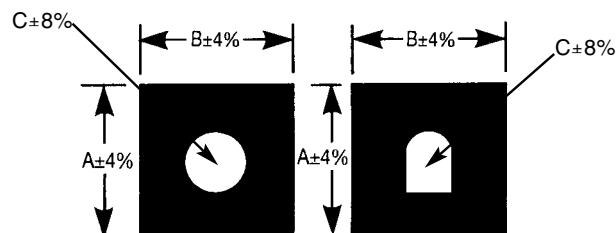

For other sizes contact factory.

QUICK REFERENCE CHART LOAD — ENERGY VALUES FOR POPULAR RECTANGULAR FENDERS

L = LOAD IN POUNDS PER FOOT OF FENDER
E = ENERGY IN FOOT-POUNDS PER FOOT OF FENDER
SIZE

SIZE										
7 x 10 x 3	L	30000	62000	140000						
	E	2000	5800	13500						
8 x 10 x 3	L	14000	31000	80000						
	E	1000	2800	7000						
8 x 8 x 3	L	14000	23000	50000						
	E	1000	2800	6000						
10 x 10 x 4	L	14000	28000	53000	105000					
	E	1000	2500	5500	12500					
10 x 12 x 4	L		22000	28000	60000	150000				
	E		2500	4700	9000	17500				
12 x 12 x 5	L		22000	28000	47000	85000				
	E		2500	4700	8500	14000				
14 x 14 x 6	L			28000	43000	70000	105000			
	E			4700	8200	13000	20000			
20 x 20 x 8	L			28000	37000	43000	58000	85000		
	E			4700	7500	10700	14500	19500		

DEFLECTION IN INCHES 1 2 3 4 5 6 7 8 9 10

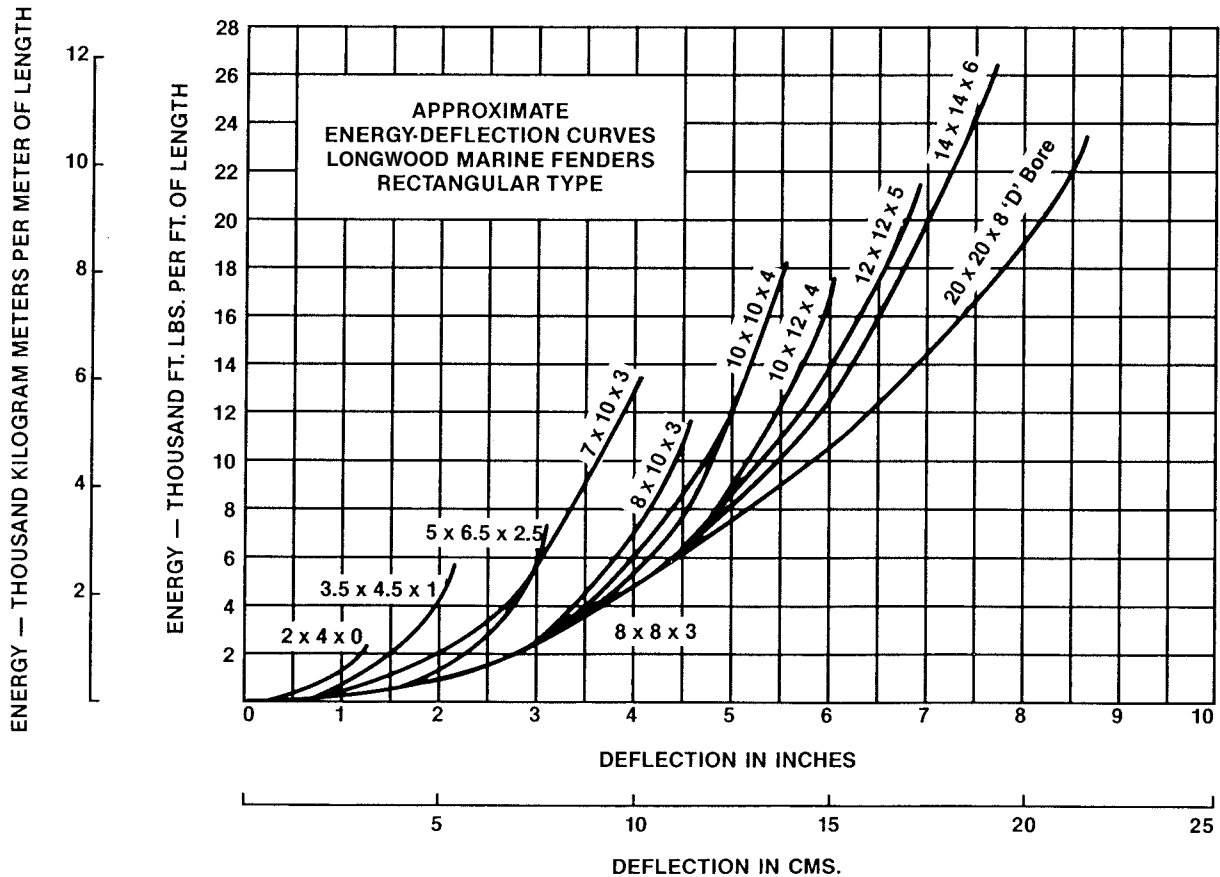
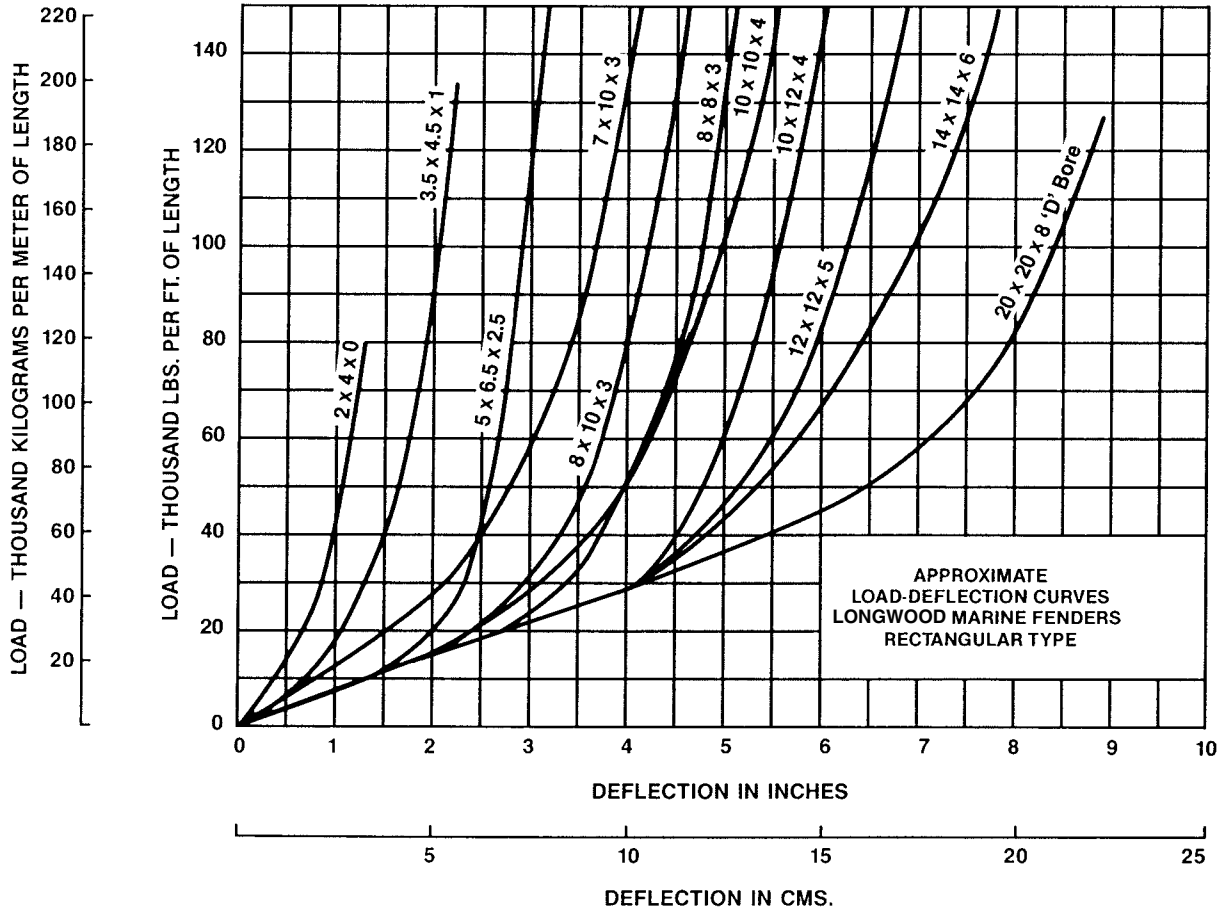

MARINE FENDER HARDWARE

TYPICAL FLEXIBLE MOUNTING OF LONGWOOD FENDERS

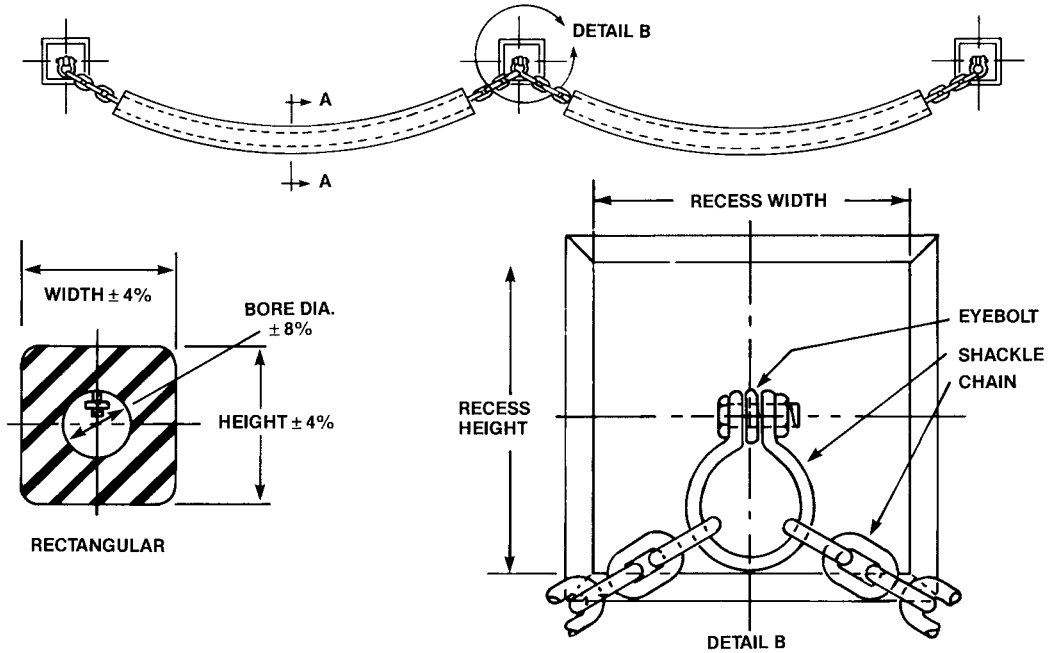

TYPICAL RIGID MOUNTING OF LONGWOOD FENDERS

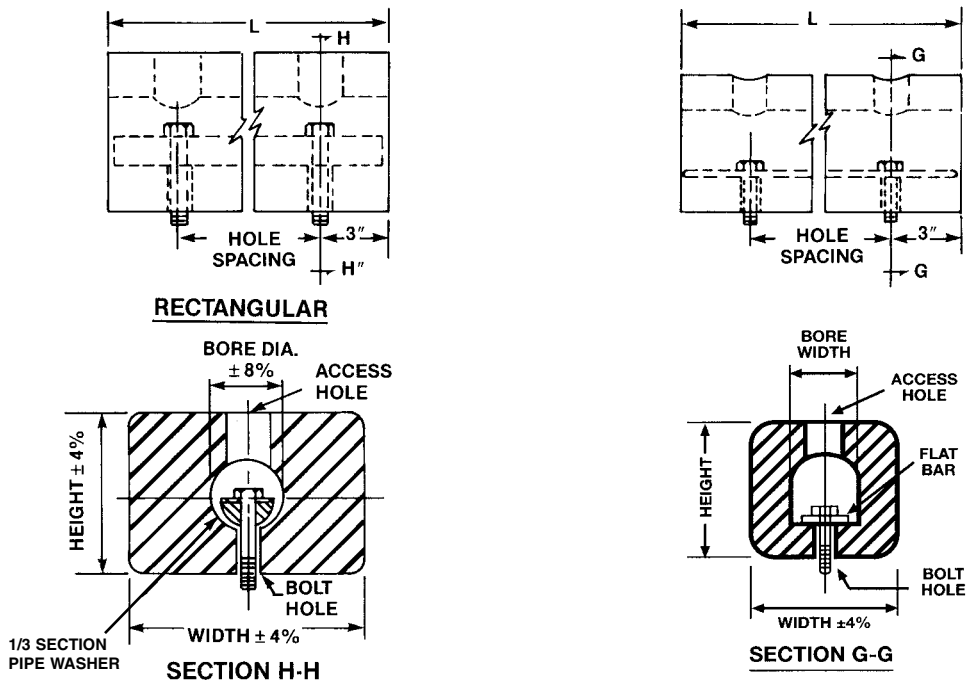

MARINE FENDER HARDWARE FLEXIBLE MOUNTING

(ALL DIMENSIONS IN INCHES UNLESS OTHERWISE SPECIFIED)

FENDER SHAPE AND SIZE	WEIGHT POUNDS/FT.	CHAIN		EYEBOLT		RECESS	
		CHAIN SIZE (A)	SHACKLE SIZE (B)	SIZE (STEEL)	SIZE (C) (CONCRETE)	WIDTH & HEIGHT	DEPTH
3-1/2" x 4-1/2" x 1"	7.4	3/8 DF	1/2	1/2 x L(D)	1/2 x 5	12	3
5" x 6-1/2" x 2-1/2"	13.5	3/8 DF	1/2	3/4 x L	3/4 x 7	14	3
7" x 10" x 3"	31.0	1/2 DF	5/8	1 x L	1 x 9-1/2	14	3
8" x 8" x 3"	28.2	1/2 DF	5/8	1 x L	1 x 9-1/2	14	3
8" x 10" x 3"	35.6	1/2 DF	5/8	1 x L	1 x 9-1/2	16	4
10" x 10" x 4"	43.1	5/8 DF	3/4	1-1/4 x L	1-1/4 x 12	16	4
10" x 12" x 4"	53.0	5/8 DF	3/4	1-1/4 x L	1-1/4 x 12	16	4
12" x 12" x 5"	61.5	5/8 DF	7/8	1-1/4 x L	1-1/4 x 12	18	5
14" x 14" x 6"	82.6	3/4 DF	1	1-1/2 x L	1-1/2 x 14	18	5
20" x 20" x 8"	171.0	3/4 DF	1	1-1/2 x L	1-1/2 x 14	18	5

FOOTNOTES

- (A) GALVANIZED
- (B) SAFETY SHACKLES
- (C) SCREW ANCHOR OR EQUAL
- (D) LENGTH

MARINE FENDER HARDWARE RIGID MOUNTING

(ALL DIMENSIONS IN INCHES UNLESS OTHERWISE SPECIFIED)

FENDER SHAPE AND SIZE	BAR SIZE	BOLT SIZE	WOOD		HOLES			WEIGHT POUNDS/FT.
			BOLT SIZE	WASHER SIZE	BOLT HOLE DIA.	ACCESS HOLE DIA.	HOLE SPACING	
3-1/2 x 4-1/2 x 1	1/2 (H)	1/2 x 6-1/2	1/2 x L (D)	.100	5/8	1-3/8	18	7.7
5 x 6-1/2 x 2-1/2	2 (H)	1/2 x 5-3/4	1/2 x L	.100	5/8	1-3/8	14	14.1
7 x 10 x 3	2-1/2 (H)	3/4 x 9-1/4	3/4 x L	.160	7/8	1-7/8	16	32.2
8 x 8 x 3	2-1/2 (H)	3/4 x 9-3/4	3/4 x L	.160	7/8	1-7/8	16	29.1
8 x 8 x (3 x 3)	3/8 X 2-1/2 (E)	3/4 x 9-3/4	3/4 x L	.160	7/8	1-7/8	16	28.7
8 x 10 x 3	2-1/2 (H)	7/8 x 10-3/4	7/8 x L	.160	1-1/8	2-1/4	16	37.3
8 x 10 x (3 x 3)	3/8 X 2-1/2 (E)	7/8 x 10-3/4	7/8 x L	.160	1-1/8	2-1/4	16	36.6
10 x 10 x 4	3 1/2 (H)	7/8 x 10-1/2	7/8 x L	.160	1-1/8	2-1/4	14	44.7
10 x 10 x (4 x 4)	3/8 X 3-1/2 (E)	7/8 x 10-1/2	7/8 x L	.160	1-1/8	2-1/4	14	43.8
10 x 12 x 4	3 1/2 (H)	1 x 11-1/2	1 x L	.160	1-1/4	2-1/2	14	54.9
10 x 12 x (4 x 4)	3/8 X 3-1/2 (E)	1 x 11-1/2	1 x L	.160	1-1/4	2-1/2	14	54.1
12 x 12 x 5	4 (H)	1 x 12	1 x L	.160	1-1/4	2-1/2	14	63.6
12x12x(6x6)	1/2x5-1/2 (E)	1 x 12	1 x L	.160	1-1/4	2-1/2	14	59.6
14 x 14 x 6	5 (H)	1-1/4 x 12	1-1/8 x L	.160	1-3/8	2-3/4	12	85.7
14x14x(6x6)	1/2x5-1/2 (E)	1-1/4 x 12	1-1/8 x L	.160	1-3/8	2-3/4	12	82.0
14 x 14 x (7 x 7)	5/8 X 6 (E)	1-1/4 x 12	1-1/8 x L	.160	1-3/8	2-3/4	12	77.8
20 x 20 x 8	7 (H)	1-1/2 x 12	1-1/2 x L	.160	1-1/2	3	10	178.9

FOOTNOTES

- (D) LENGTH
- (E) FLAT BAR
- (H) 1/3 SECTION PIPE WASHER

D-SHAPED FENDERS

Longwood manufactures D-Series fenders with either a cylindrical or a “D” shaped bore to provide for varying mounting requirements. Designed for use on tugs and barges, they offer long term durability for applications where repeated compression cycles are encountered in pushing service. They also offer the excellent physical characteristics needed to handle the high loading which occurs both on initial contact, and throughout the service cycle.

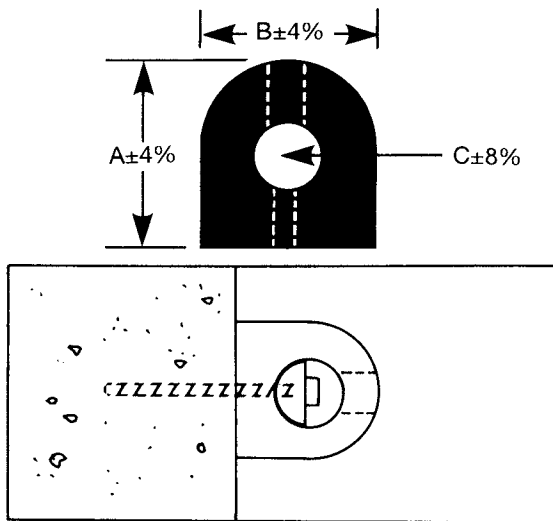

“D” SERIES
Cylindrical Bore

A HEIGHT		B WIDTH		C BORE		APPROX.	
IN	MM	IN	MM	IN	MM	LBS/FT	KG/M
5	127	6½	165	2½	64	12	18
6	152	5	127	2½	64	11	17
6	152	6	152	3	76	13	19
6	152	8	203	3	76	17	26
8	203	8	203	3	76	26	38
8	203	10	254	3	76	32	47
10	254	10	254	4	102	39	58
10	254	12	305	4	102	47	70
12	305	12	305	5	127	56	83
14	356	14	356	6	152	75	112
14	356	18	457	Double 3	Double 76	104	155

Standard production lengths available up to 20 ft.
Contact factory if longer lengths are required.

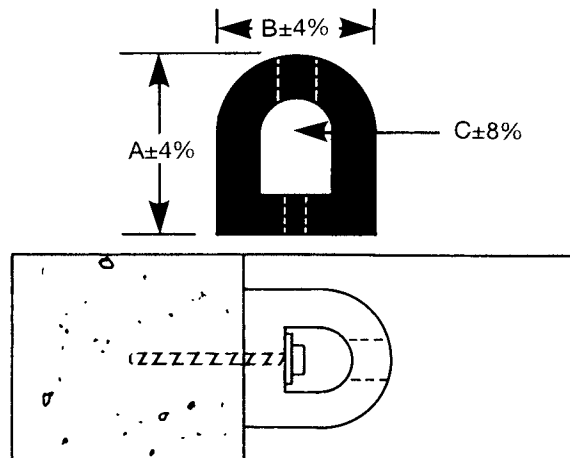

“D” SERIES
“D” Shaped Bore

SIZE		A HEIGHT		B WIDTH		C BORE		APPROX.	
IN	MM	IN	MM	IN	MM	IN	MM	LBS/FT	KG/M
3	76	2½	67	3¾	81	2¾	60x41	2	3
4	102	4	102	4	102	2x2	51x51	5	8
4½	114	3¾	98	4¾	113	2½	75x41	6	9
5	127	5	127	5	127	2	51x51	10	14
6	152	6	152	6	152	3	76x76	12	18
8	203	8	203	8	203	4	102x102	22	33
10	254	10	254	10	254	4	102x102	38	57
12	305	12	305	12	305	6	152x152	49	73
14	356	14	356	14	356	7	178x178	67	100

Standard production lengths available up to 20 ft.
Contact factory if longer lengths are required.

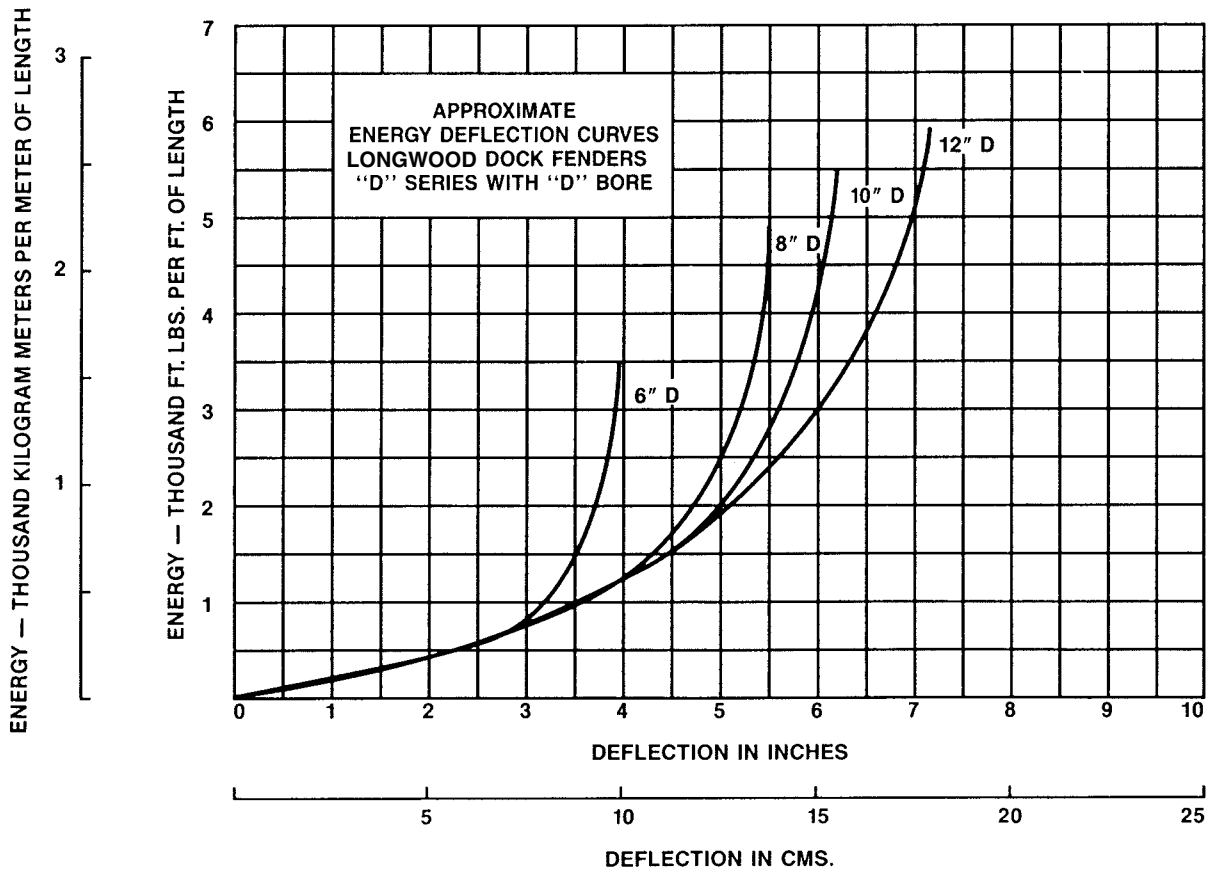
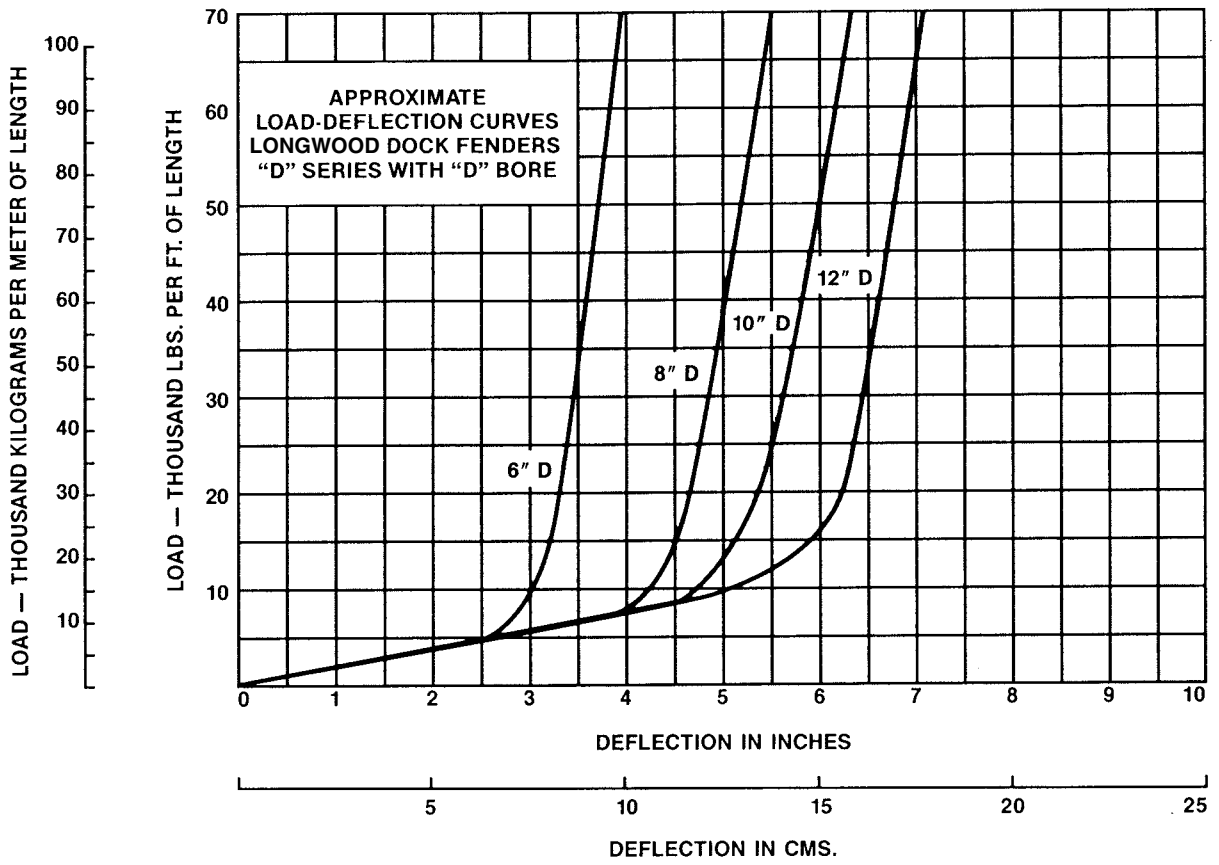

MARINE FENDER HARDWARE

TYPICAL RIGID MOUNTING OF LONGWOOD FENDERS

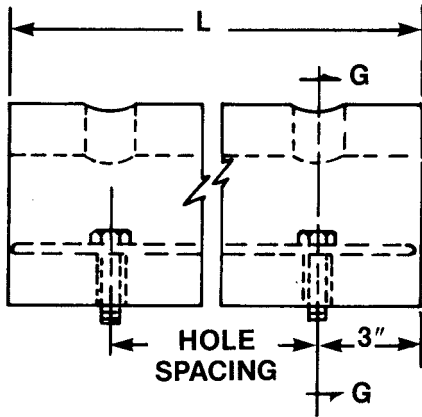

"D" SHAPE

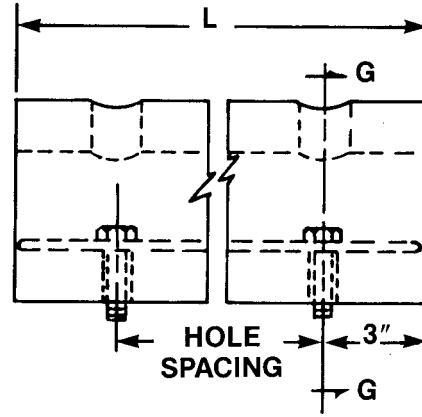

"D" SHAPE

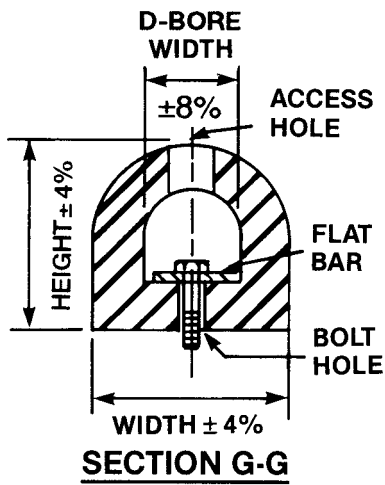

SECTION G-G

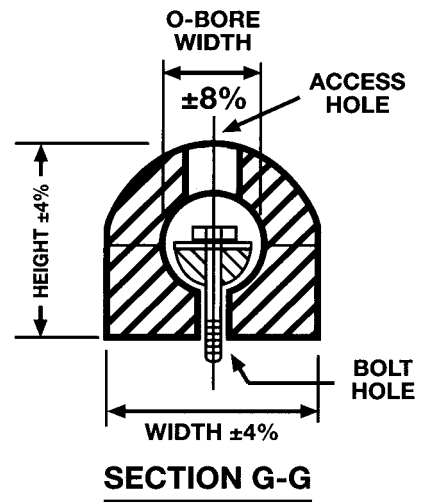

SECTION G-G

MARINE FENDER HARDWARE RIGID MOUNTING

(ALL DIMENSIONS IN INCHES UNLESS OTHERWISE SPECIFIED)

FENDER SHAPE AND SIZE	BAR SIZE	CONCRETE BOLT SIZE (C)	WOOD		HOLES			WEIGHT POUNDS/FT.
			BOLT SIZE	WASHER SIZE	BOLT HOLE DIA.	ACCESS HOLE DIA.	HOLE SPACING	

“D” SHAPE, “D” BORE HEIGHT x BASE W. x BORE W.

4 x 4 x 2	3/16 x 1-1/2 F (E)	1/2 x 5 (D)	1/2 x L	.100	5/8	1-3/8	18	5.2
5 x 5 x 2	3/16 x 1-1/2 F	1/2 x 5	1/2 x L	.100	5/8	1-3/8	18	8.5
6 x 6 x 3	1/4 x 2-1/2 F	5/8 x 6	5/8 x L	.160	3/4	1-5/8	18	11.9
8 x 8 x 4	3/8 x 3-1/2 F	3/4 x 10-1/2	3/4 x L	.160	1-1/4	2-1/2	16	21.4
10 x 10 x 4	1/2 x 3-1/2 F	1 x 11-1/2	1 x L	.160	1-1/4	2-1/2	16	36.5
12 x 12 x 6	1/2 x 5-1/2 F	1-1/8 x 12	1-1/8 x L	.160	1-3/8	2-3/4	14	47.6

“D” SHAPE, CIRC. BORE HEIGHT x BASE W. x BORE W.

6 x 6 x 3	2-1/2 (H)	5/8 x 6	5/8 x L	.160	3/4	1-5/8	18	12.5
8 x 8 x 3	2-1/2	3/4 x 10-1/2	3/4 x L	.160	1-1/4	2-1/2	16	24.6
10 x 10 x 4	3	1 x 11-1/2	1 x L	.160	1-1/4	2-1/2	16	37.8
12 x 12 x 5	4	1-1/8 x 12	1-1/8 x L	.160	1-3/8	2-3/4	14	53.7
14 x 14 x 6	5	1-1/8 x 14	1-1/8 x L	.160	1-3/8	2-3/4	12	72.5

FOOTNOTES

- (C) SCREW ANCHOR OR EQUAL
- (D) LENGTH
- (E) FLAT BAR
- (H) 1/3 SECTION PIPE WASHER

WING TYPE FENDERS

Wing Type fenders are designed for vessel mounting. They combine the impressive energy absorption capabilities of a cylindrical design with the convenience of wing mounting. They are available from 3" to 12" O.D. to tailor the protection to the vessel's size and purpose: from pleasure craft through pilot boats, heavy tugs, barges and ferries.

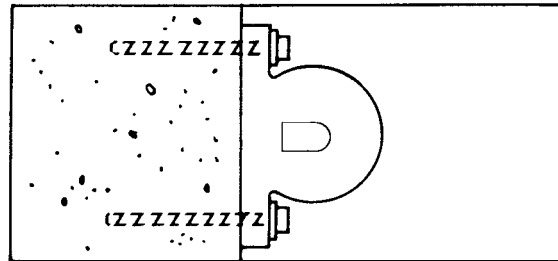
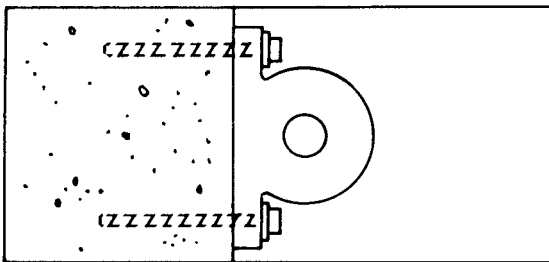
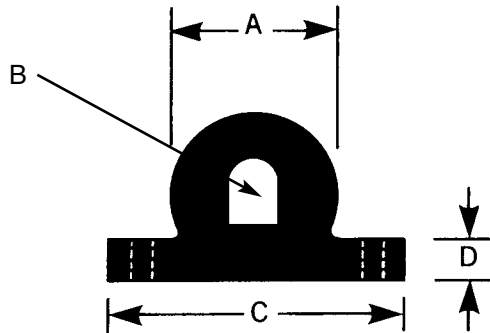
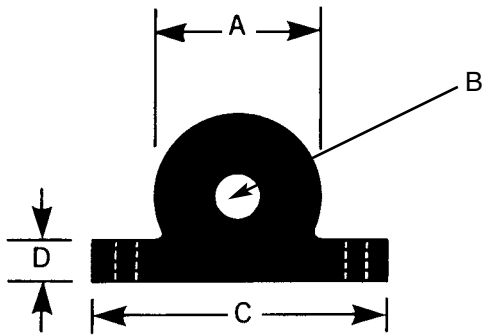

WING TYPE

A O.D.		B BORE		C FLANGE BASE WIDTH		D FLANGE THICKNESS		APPROX.	
IN	MM	IN	MM	IN	MM	IN	MM	LBS/FT	KG/M
3	76	1	25	6	152	3/4	19	5	7
4	102	2	51	6 1/2	165	1	25	7	10
4	102	1	25	6 1/2	165	1	25	8	12
6	152	2	51	9 1/2	241	1 1/2	38	18	25
6	152	3	76	9	229	1 1/2	38	15	22
6	152	4	102x102	9 1/2	241	1 1/2	38	16.6	24.4
8	203	4	102	12	305	2	51	27	40
10	254	3	76	16	406	2 1/2	64	49	73
10	254	4	102	16	406	2 1/2	64	46	68
12	305	6	152	18	457	3	76	61	91

Standard production lengths available up to 20 ft.
Contact factory if longer lengths are required.

ENERGY — THOUSAND KILOGRAM METERS PER METER OF LENGTH

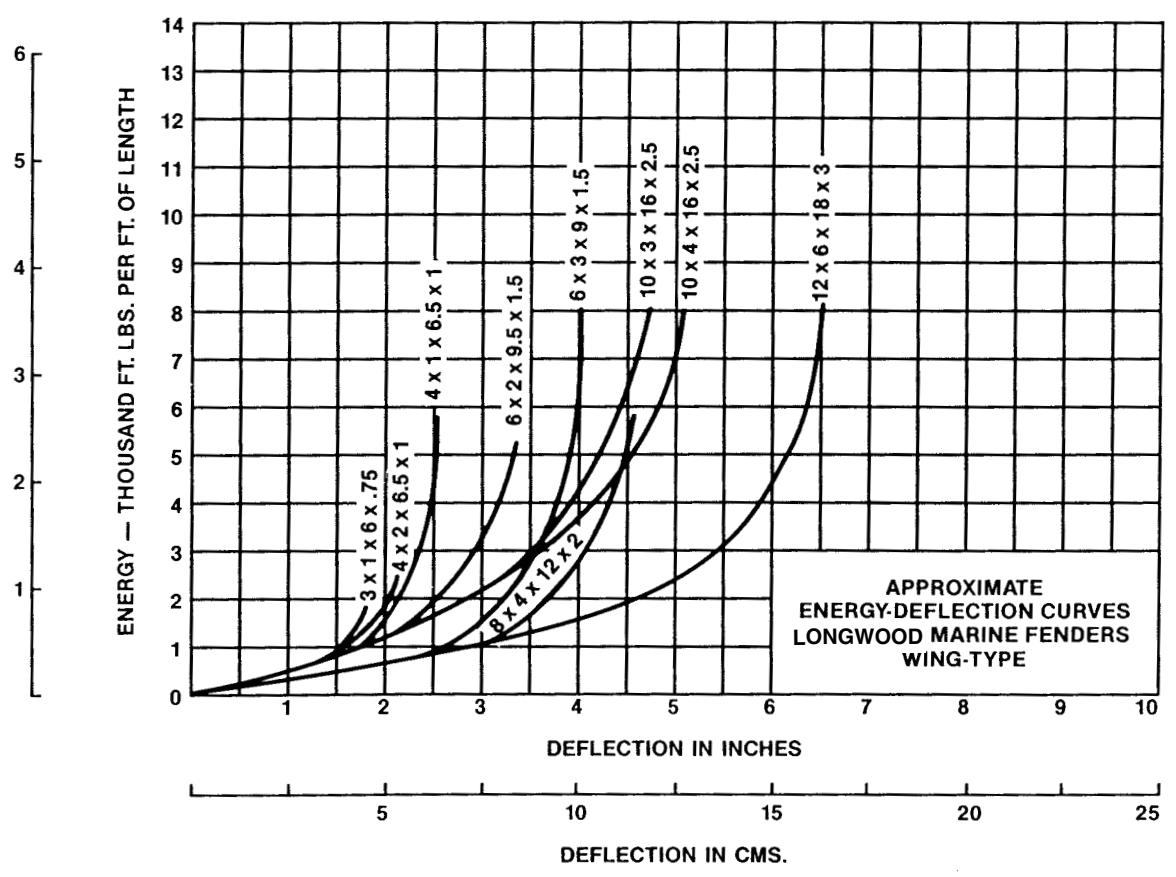

LOAD — THOUSAND KILOGRAMS PER METER OF LENGTH

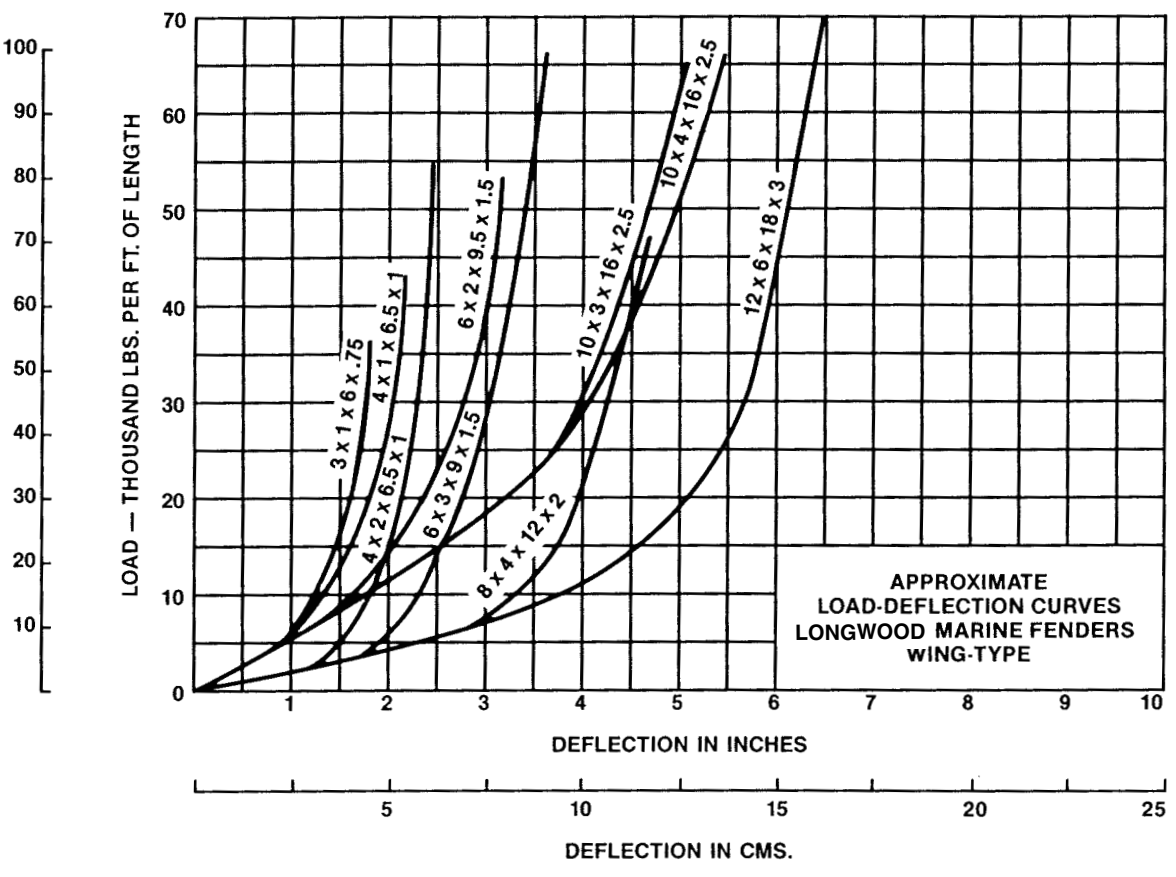

MARINE FENDER HARDWARE

TYPICAL RIGID MOUNTING OF LONGWOOD FENDERS

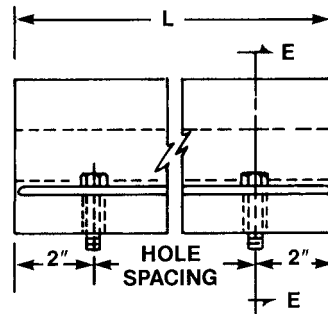

WING TYPE

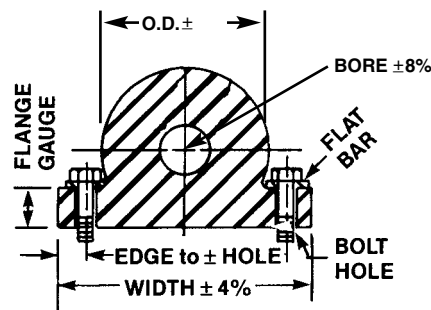

SECTION E-E

ALL DIMENSIONS IN INCHES UNLESS OTHERWISE SPECIFIED

FENDER SHAPE AND SIZE	BAR SIZE	CONCRETE BOLT SIZE (C)	WOOD		HOLES			WEIGHT POUNDS/FT.
			BOLT SIZE	WASHER SIZE	BOLT HOLE DIA.	ACCESS HOLE DIA.	HOLE SPACING	

WING TYPE (O.D. x I.D. x FLANGE WIDTH x FLANGE GAUGE)

3 x 1 x 6 x 3/4	3/16 x 1F (E)	3/8 x 4-1/2	3/8 x L (D)	.100	1/2	-	18	4.6
4 x 1 x 6-1/2 x 1	3/16 x 1F	3/8 x 4-3/4	3/8 x L	.100	1/2	-	18	7.6
4 x 2 x 6-1/2 x 1	3/16 x 1F	3/8 x 4-3/4	3/8 x L	.100	1/2	-	18	6.5
6 x 2 x 9-1/2 x 1-1/2	1/4 x 1-1/2 F	5/8 x 6-3/4	5/8 x L	.160	3/4	-	13	16.4
6x(4x4)x9-1/2 x 1-1/2	1/4 x 1-1/2 F	5/8 x 6-3/4	5/8 x L	.160	3/4	-	13	16.6
8 x 4 x 12 x 2	5/16 x 1-3/4 F	5/8 x 7-1/2	5/8 x L	.160	3/4	-	10	25.6
10 x 3 x 16 x 2-1/2	3/8 x 2-1/2 F	3/4 x 8-7/8	3/4 x L	.160	1	-	7-1/2	47.5
10 x 4 x 16 x 2-1/2	3/8 x 2-1/2 F	3/4 x 8-7/8	3/4 x L	.160	1	-	7-1/2	44.8
12 x 6 x 18 x 3	7/16 x 2-1/2 F	7/8 x 10	7/8 x L	.160	1-1/4	-	6	68.5

FOOTNOTES

- (C) SCREW ANCHOR OR EQUAL
- (D) LENGTH
- (E) FLAT BAR

TRAPEZOIDAL DOCK FENDERS



Longwood Trapezoidal dock fenders have high energy absorption and low reaction load transmission characteristics similar to V-Series fenders. However, the engineering of the Trapezoidal base results in a smoother loading curve and more uniform deceleration. This produces an efficiency which allows a smaller section of Trapezoidal fender to absorb a greater amount of impact than other cross sections.

Two types of Trapezoidal fender are available to offer installation and design flexibility.

The "R-Series" is designed for mounting directly to open faced structures using a steel bar through the bore. They may also be used behind, or on the face of, conventional timbering.

A "W-Series" Trapezoidal fender is extruded with wings which can incorporate an optional external mounting groove. They are installed with metal mounting bars.

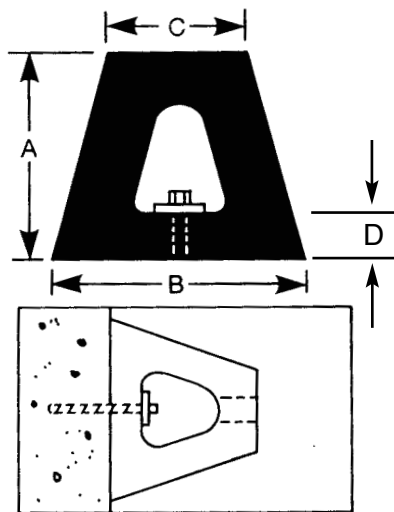

OPTION:
AVAILABLE WITH
GROOVES AND METAL
BARS FASTENED IN
PLACE.

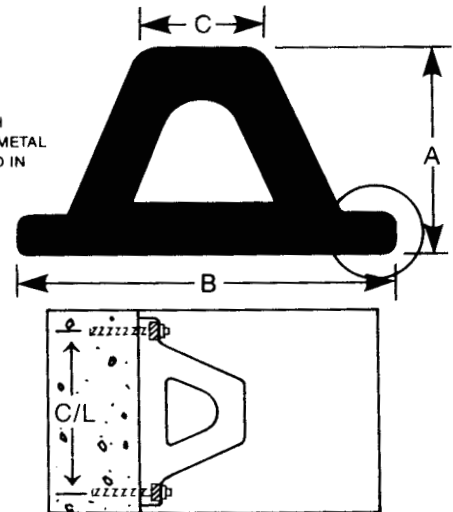

TRAPEZOIDAL — "R" SERIES
Inside Bar Mounted

TRAPEZOIDAL — "W" SERIES
Metal Bar Mounted

Code	A Height		B Base		C Top		D Base		Approx.	
	IN	MM	IN	MM	IN	MM	IN	MM	LBS/FT	KG/M
10R	10	254	12-3/4	324	5-1/2	140	2-1/4	57	37	55
13R	13	330	16-5/8	422	7-3/8	187	2-3/4	70	61	91
15R	15	381	19-1/8	486	8-5/8	219	2-3/4	70	81	121
17R	17	432	21-5/8	549	9-7/8	251	2-7/8	73	104	155
20R	20	508	23-1/4	590	11-1/4	286	3-3/4	95	138	205

Code	A Height		B Base		A Top		Approx.		C/L	
	IN	MM	IN	MM	IN	MM	LBS/FT	KG/M	IN	MM
10W	10	254	18-1/2	470	5-1/2	140	44	65	15	381
13W	13	330	21-1/2	546	7-3/8	187	68	101	18	462
15W	15	381	24-3/4	629	8-5/8	219	93	138	21	539

Standard production lengths available up to 20 ft.
Contact factory if longer lengths are required.

Standard production lengths available up to 20 ft.
Contact factory if longer lengths are required.

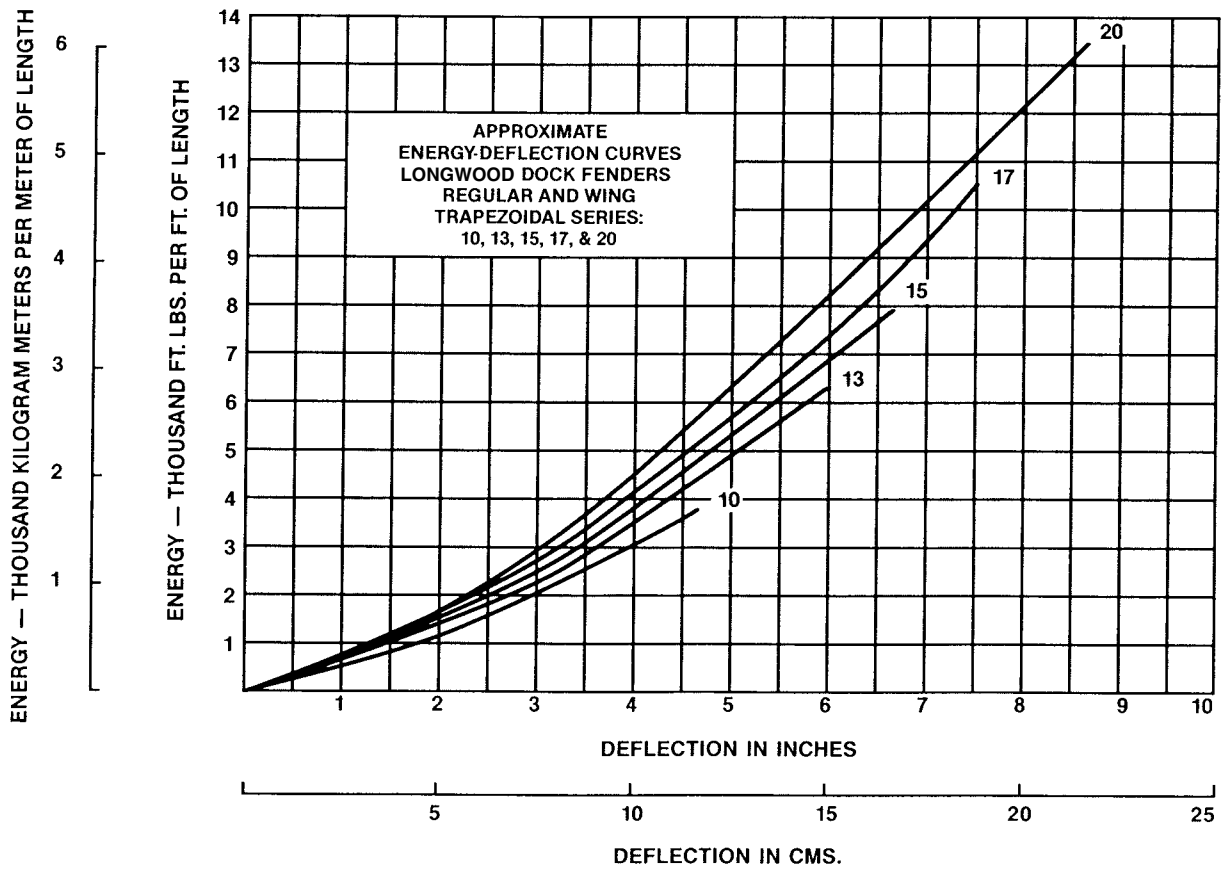
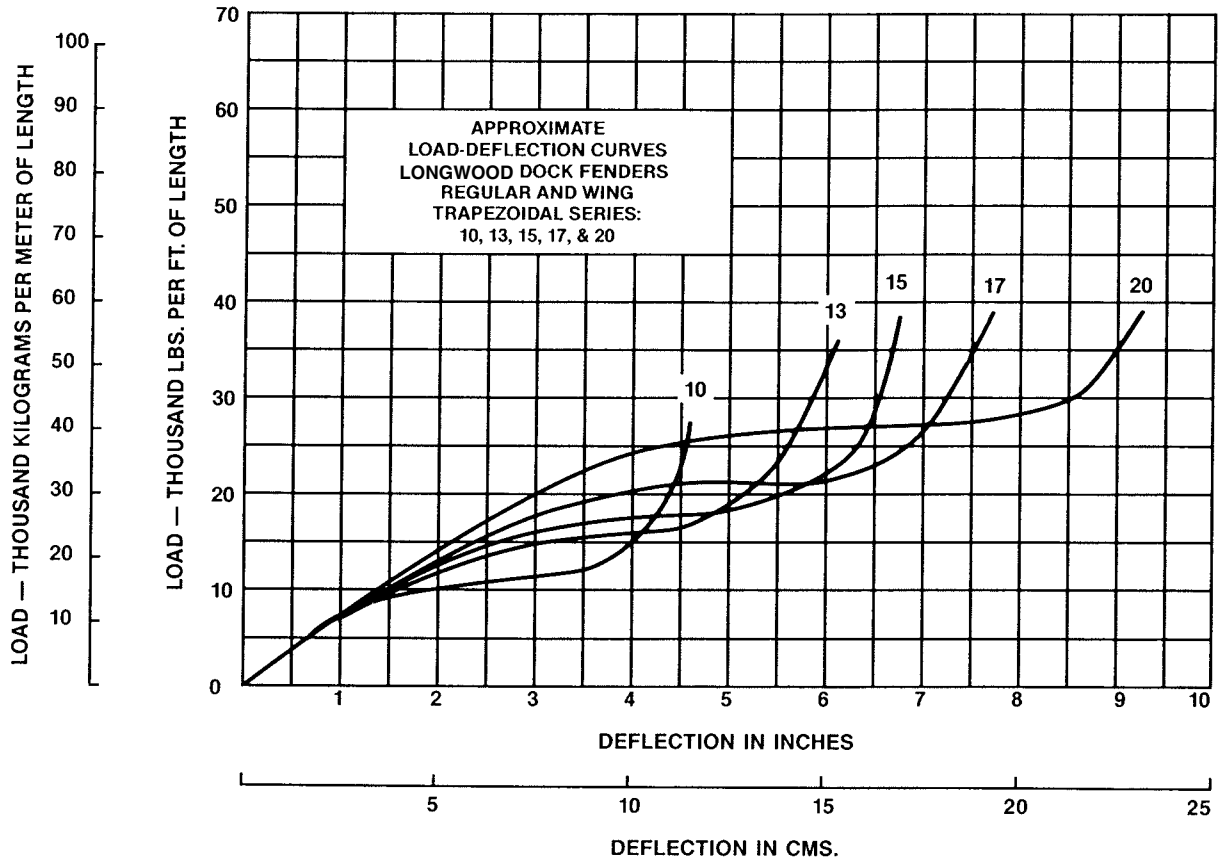

MARINE FENDER HARDWARE

TYPICAL RIGID MOUNTING OF LONGWOOD FENDERS

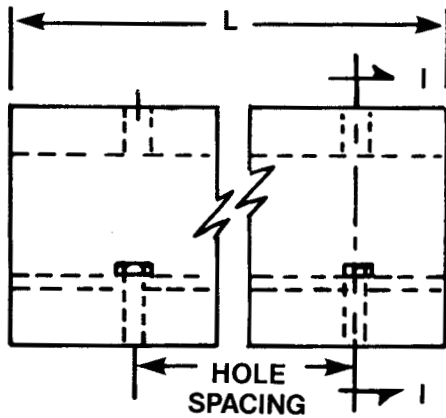

TRAPEZOIDAL
"R" SERIES

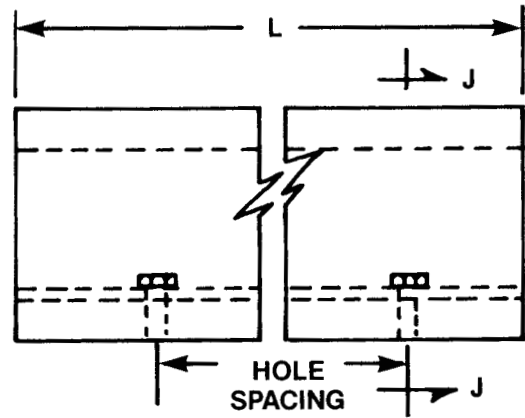

WING TRAPEZOIDAL
"W" SERIES

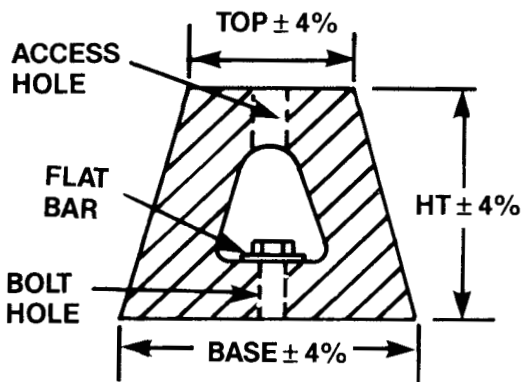

SECTION I-I

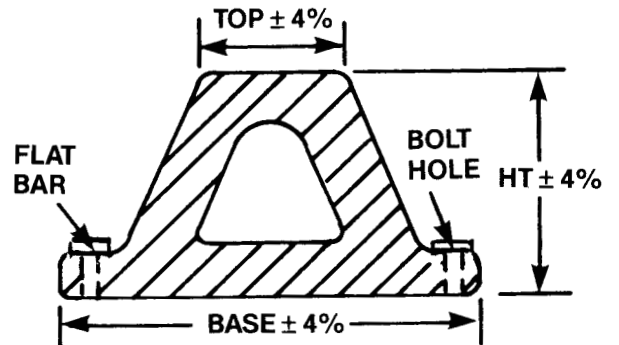

SECTION J-J

MARINE FENDER HARDWARE RIGID MOUNTINGS

(ALL DIMENSIONS IN INCHES UNLESS OTHERWISE SPECIFIED)

FENDER SHAPE & SIZE	BAR SIZE	CONCRETE BOLT SIZE (C)	WOOD		HOLES			WEIGHT POUNDS/FT.
			BOLT SIZE	WASHER SIZE	BOLT HOLE DIA.	ACCESS HOLE DIA.	HOLE SPACING	

TRAPEZOIDAL "R" SERIES (HEIGHT x BASE WIDTH)

10 x 12-3/4	5/8 x 4 F (E)	1 x 8-7/8	1 x L (D)	.160	1-1/4	2	12	35.6
13 x 16-5/8	5/8 x 5 F	1-1/4 x 12	1-1/4 x L	.160	1-1/2	2-1/2	10	58.5
15 x 19-1/8	5/8 x 6 F	1-1/2 x 12	1-1/2 x L	.160	1-3/4	3	10	77.0
17 x 21-5/8	3/4 x 7 F	1-1/2 x 12	1-1/2 x L	.160	1-3/4	3	8	99.8
20 x 23-1/4	3/4 x 8 F	1-3/4 x 12	1-3/4 x L	.160	2	3-1/2	8	135.3

TRAPEZOIDAL "W" SERIES HEIGHT x BASE WIDTH

10 x 18-1/2	5/8 x 3 F	1 x 8-7/8	1 x L	.160	1-1/4		12	42.0
13 x 21-1/2	5/8 x 3 F	1-1/4 x 12	1-1/4 x L	.160	1-1/2		10	66.0
15 x 24-3/4	5/8 x 3 F	1-1/2 x 12	1-1/2 x L	.160	1-3/4		10	85.0

(D) LENGTH

(E) FLAT BAR

(C) SCREW ANCHOR OR EQUAL

V-SERIES ARCH FENDER



Longwood's Arch design is engineered to take advantage of the elasticity inherent in rubber. Compared to other section profiles of the same size, Arch fenders will absorb a greater amount of energy and allow less of a reaction load to reach the structure.

Longwood Arch fenders are easy to install and require virtually no maintenance. They are used in combination with conventional wood facings in a system where the timbering spreads the load over a wider area and a greater number of fender segments. This reduces load concentrations and increases the protection for the structure.

Fastened top-to-top and installed between timbered surfaces, they provide an even greater cushioning effect.

As a result, dock design requirements (and costs) can be reduced, or larger and heavier vessels can be accommodated.

Other advantages include:

1. Mounting hardware is fully exposed. Water drains off.
2. Fender is mechanically attached to mounting hardware.
3. All mounting hardware is stainless steel or treated for corrosion resistance.
4. Mounting hardware components or rubber fender can be replaced separately if damaged.

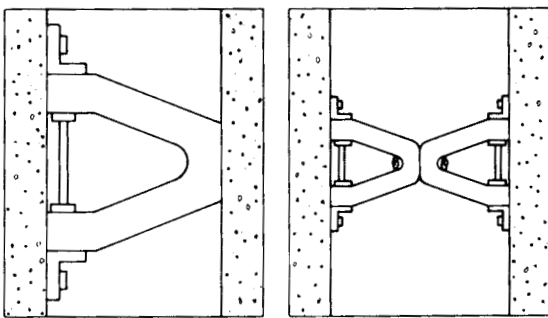
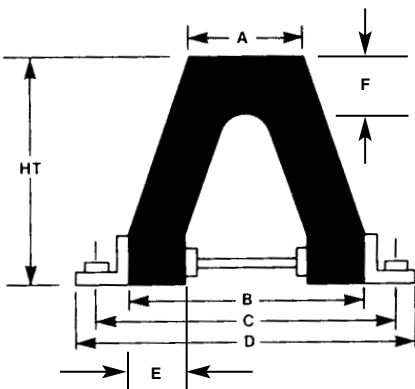

LONGWOOD ARCH DOCK FENDER SPECIFICATIONS

MODEL NO.	HT		A		B		C		D		E		F		Energy Absorbed		Reaction Force	
	IN	MM	IN	MM	IN	MM	IN	MM	IN	MM	IN	MM	IN	MM	KIP-FT/FT	TON-M/M	KIPS/FT	TON /M
12V	12	305	7.5	191	13	330	17	432	28	508	3-1/4	83	3-1/4	83	6.3	2.8	18.0	26.8
16V	16	406	11.7	275	21	533	25	660	29	737	5	127	5	127	11.5	5.2	23.0	34.3
20V	20	508	12.0	303	23	584	29	737	33	638	5-1/2	140	5-1/2	140	15.0	6.8	23.0	34.3

- Being extruded, length of fender can vary to meet specific requirements.
- Performance value tolerances equal $\pm 10\%$.

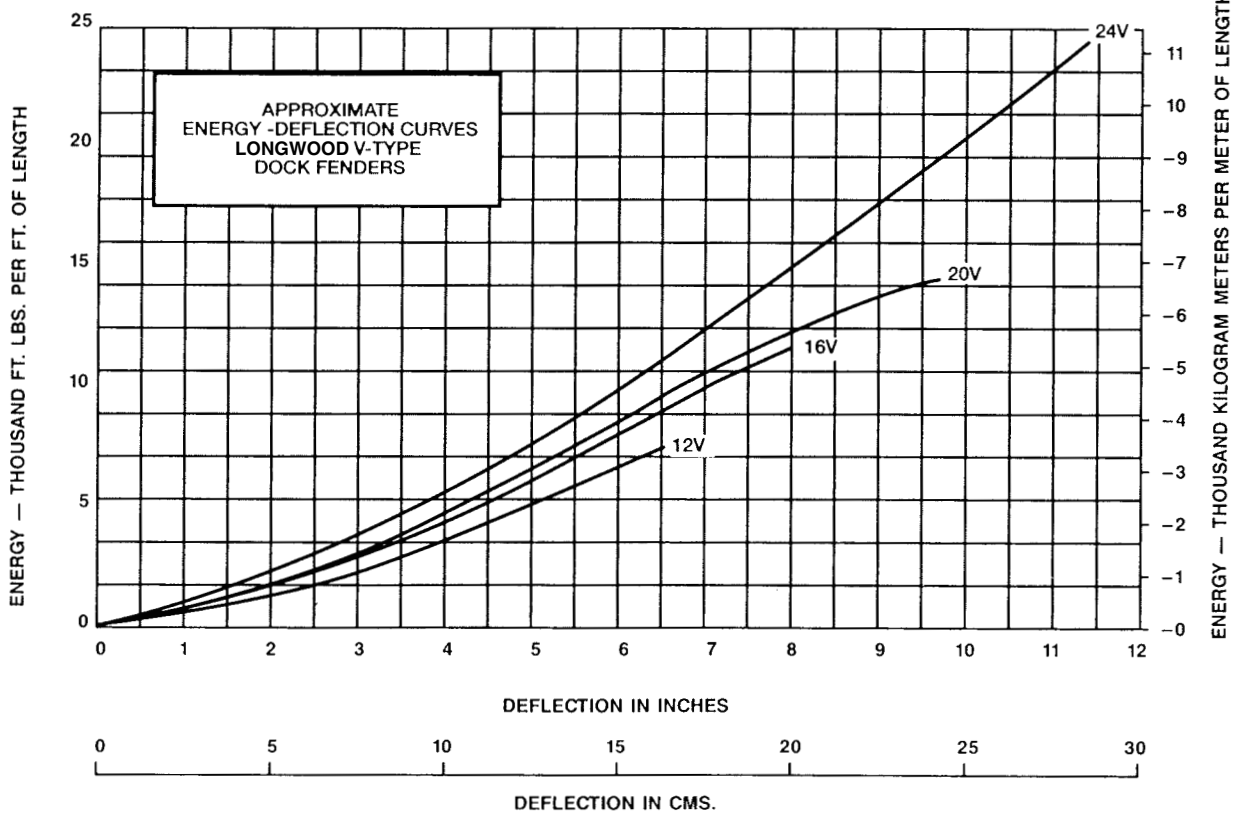
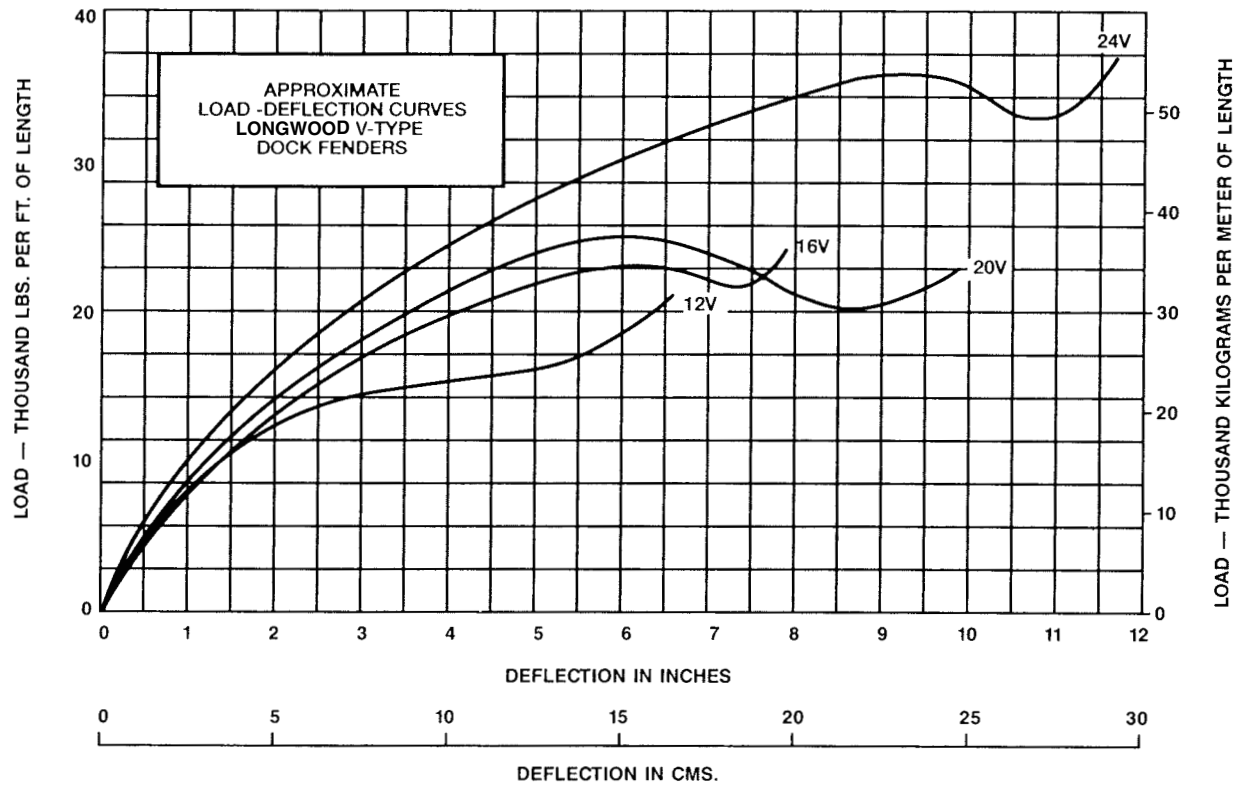

MARINE FENDER HARDWARE RIGID MOUNTING

(ALL DIMENSIONS IN INCHES UNLESS OTHERWISE SPECIFIED)

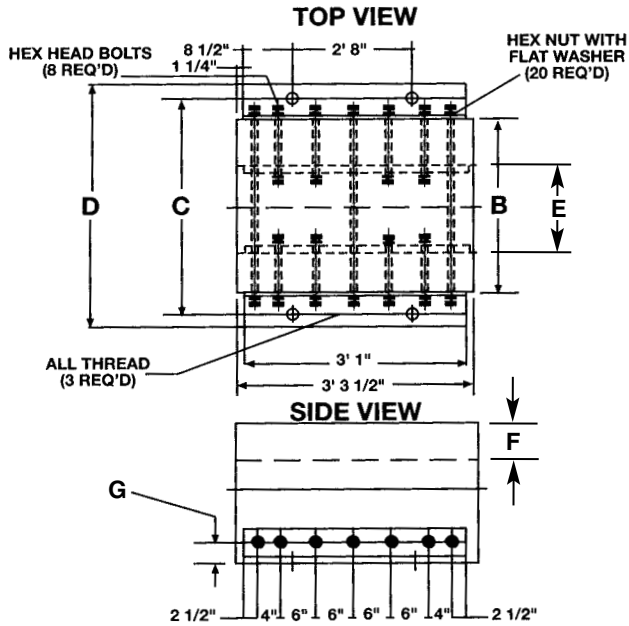

LONGWOOD ARCH SERIES (STANDARD METER LENGTH SHOWN)

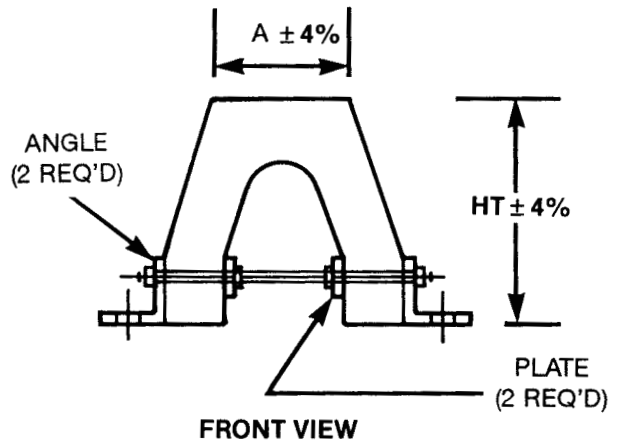

ARCH SERIES

Fender Size	Angle Size	Plate Size	All-Thread Size	Hex Bolt Size	Nut & Flat Washer Size	G	
						IN	MM
12V	3-1/2 x 3-1/2 x 1/2	1/2 x 2	1/2 x 15-1/2	1/2 x 5	1/2	2-1/2	64
16V	4 x 4 x 1/2	1/2 x 2-1/2	3/4 x 24	3/4 x 7	3/4	2-1/2	64
20V	5 x 5 x 3/4	3/4 x 2-1/2	3/4 x 26-1/2	3/4 x 8	3/4	3-1/2	89

Metal Options

1. Hot Dip Galvanized
2. Fusion Bonded Epoxy Coating
3. Stainless Steel

M-SERIES FENDERS

M-Series fenders offer protection for small vessel dock structures as well as having many industrial uses. They can protect trucks, loading docks and industrial property. They can be easily moved to meet changing conditions.

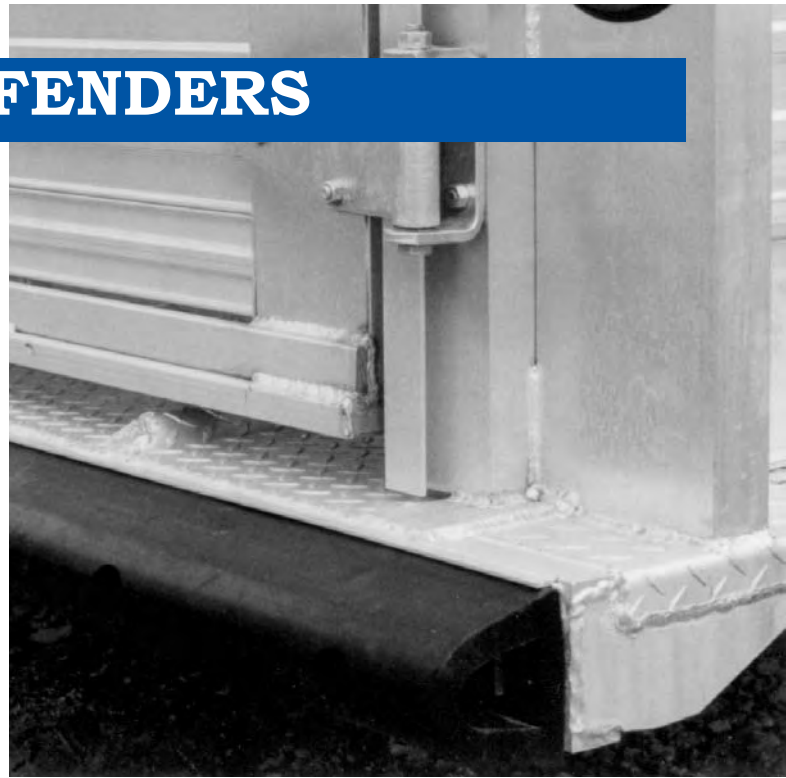

M-SERIES

CODE	A		B		C		D		E	
	IN	MM	IN	MM	IN	MM	IN	MM	IN	MM
M-2	2	51	2-1/4	57	1	25	1-1/4	32	3/8	9
M-4	3-3/4	96	4-1/2	115	2	51	2	51	1-1/2	38
M-6	6	152	6-3/4	172	2-7/8	73	3	76	2-3/8	60

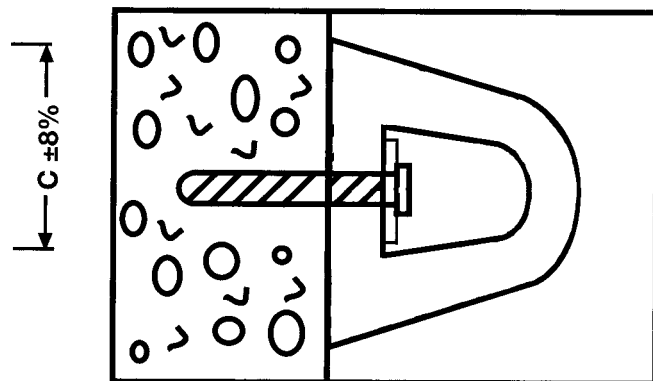
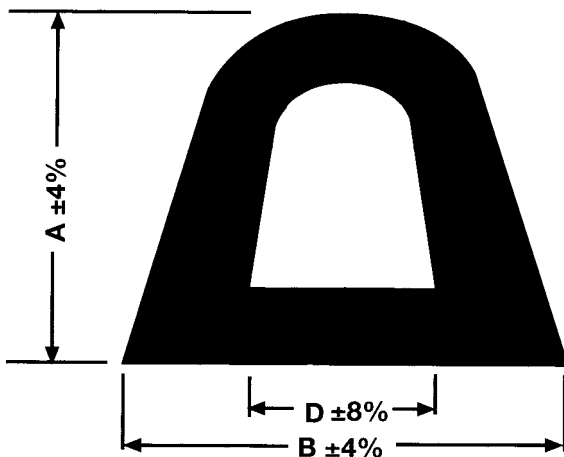

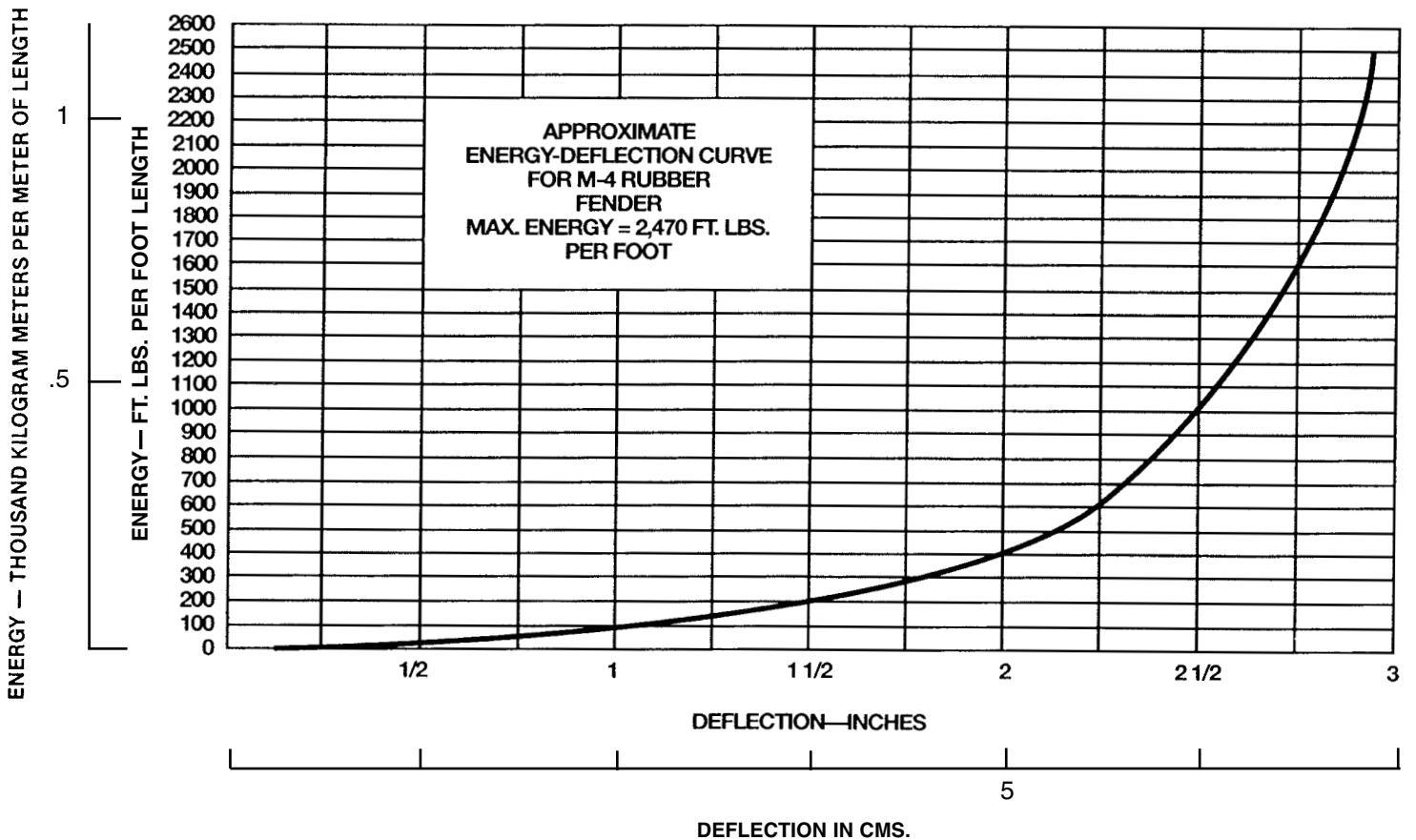
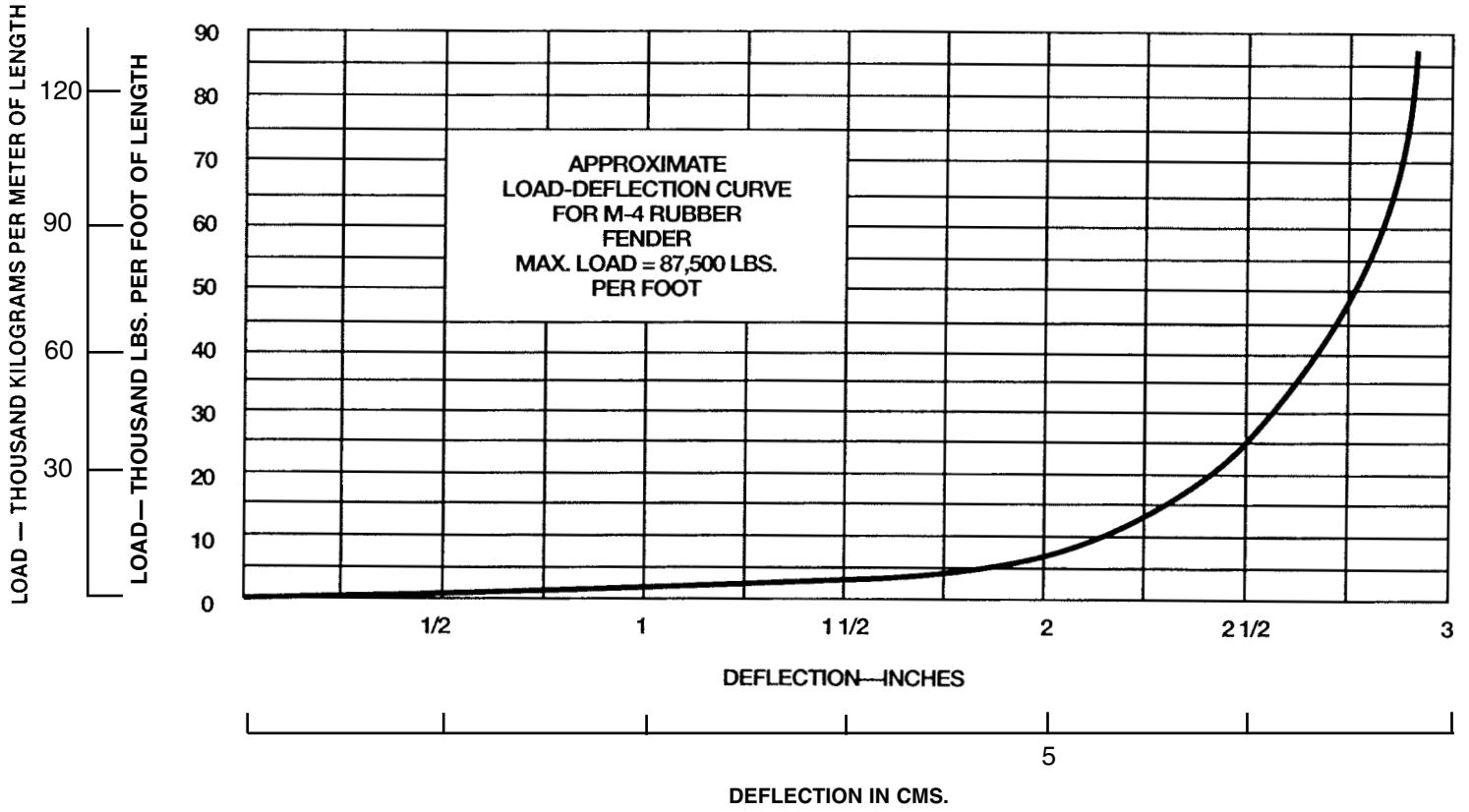

MARINE FENDER HARDWARE

TYPICAL RIGID MOUNTING OF LONGWOOD FENDERS

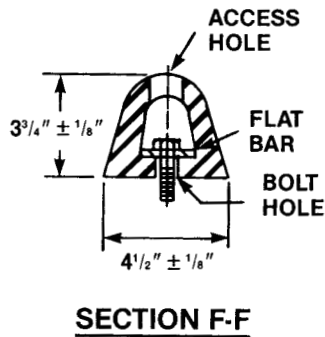
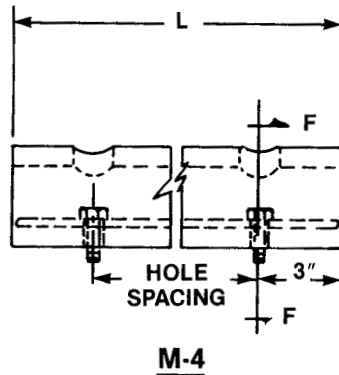

MARINE FENDER HARDWARE RIGID MOUNTINGS

(ALL DIMENSIONS IN INCHES UNLESS OTHERWISE SPECIFIED)

FENDER SHAPE AND SIZE	BAR SIZE	CONCRETE BOLT SIZE (C)	WOOD		HOLES			WEIGHT POUNDS/FT.
			BOLT SIZE	WASHER SIZE	BOLT HOLE DIA.	ACCESS HOLE DIA.	HOLE SPACING	

M SERIES (HEIGHT x BASE WIDTH)

M-4 3-3/4 x 4-1/2	3/16 x 1-1/2 F(E)	1/2 x 5	1/2 x L(D)	.100	3/4	1-3/8	18	4.5
M-6 6 x 6-3/4	1/4 x 2-1/2 F	5/8 x 6	5/8 x L	.160	3/4	1-5/8	18	12.0

FOOTNOTES

- (C) SCREW ANCHOR OR EQUAL
- (D) LENGTH
- (E) FLAT BAR

END-LOADED CYLINDRICAL FENDERS

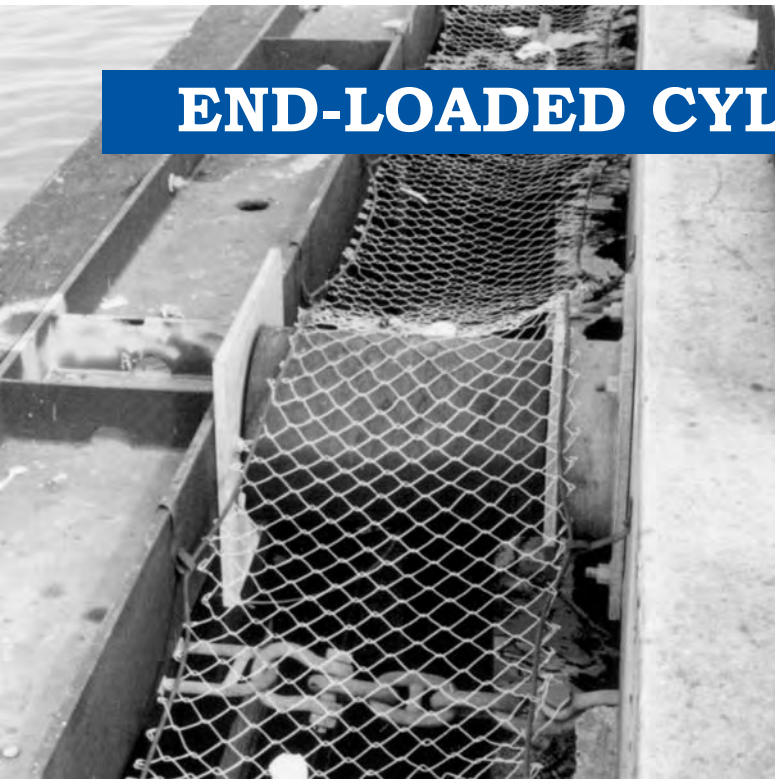

The Cylindrical fender can also be mounted horizontally and end-loaded. These fenders are used in combination with conventional wood facings where the timbering spreads the load to the fenders. The load is then applied to the fenders parallel to the axis of the bore. The length of the end-loaded fender should not exceed 1.5 times the diameter and the fender must not be allowed to compress more than 50% of its length.

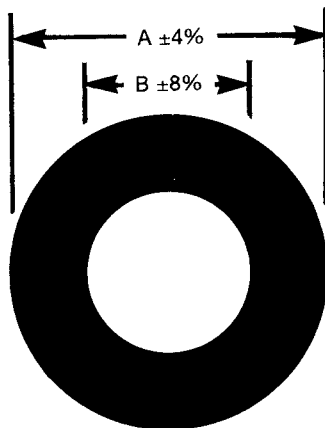

END-LOADED CYLINDRICAL					
A		B		APPROX. LBS/FT	APPROX. KG/M
O.D.	MM	O.D.	MM		
10"	254	5"	127	30	45
12"	305	6"	152	43	64
15"	381	7.5"	191	68	101
18"	457	9"	229	98	146
21"	533	10.5"	267	133	198
24"	610	12"	305	174	259
27"	686	13.5"	343	220	327

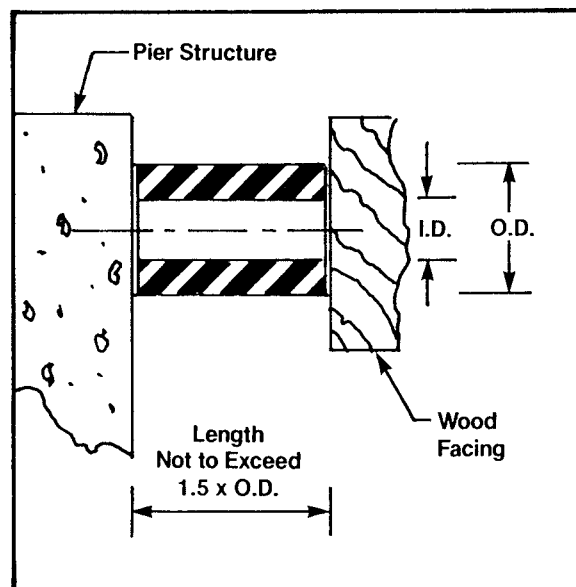

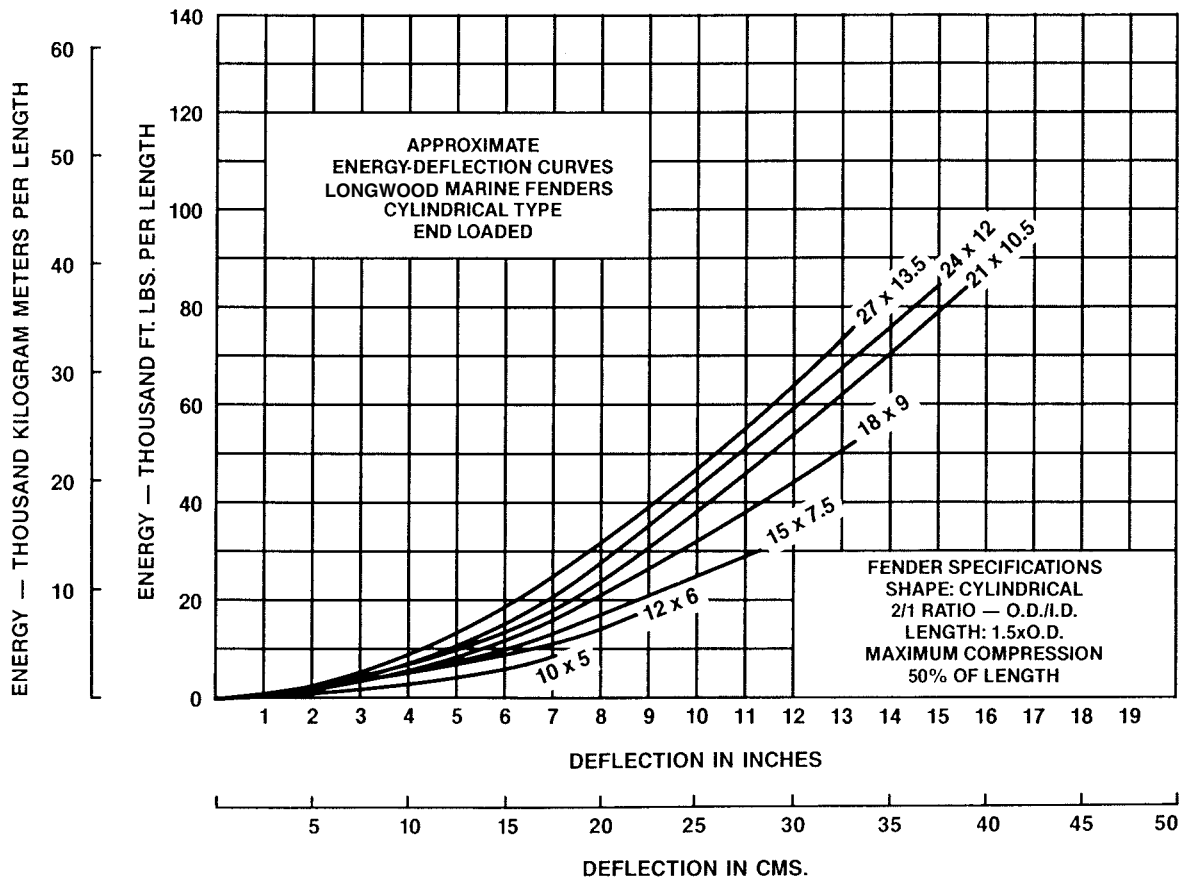
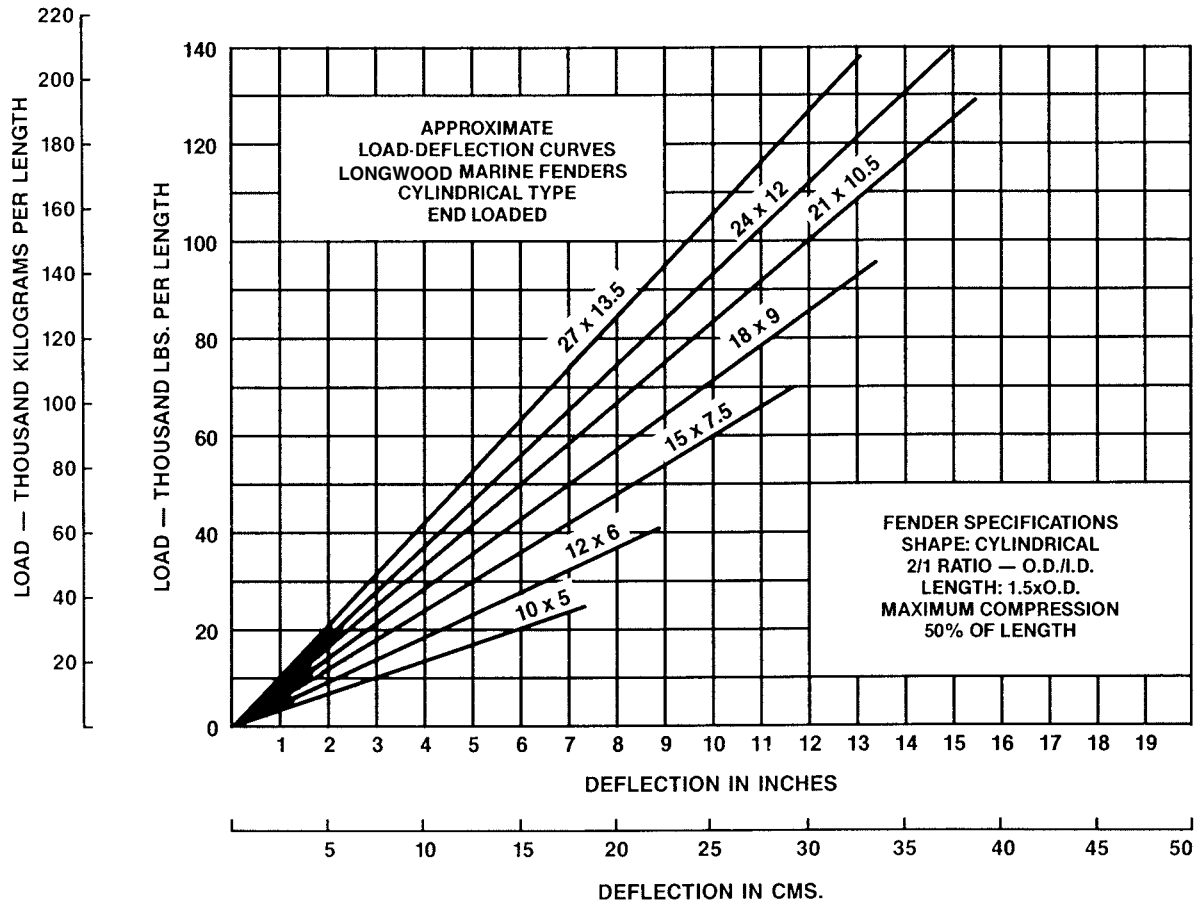

MISCELLANEOUS FENDERS

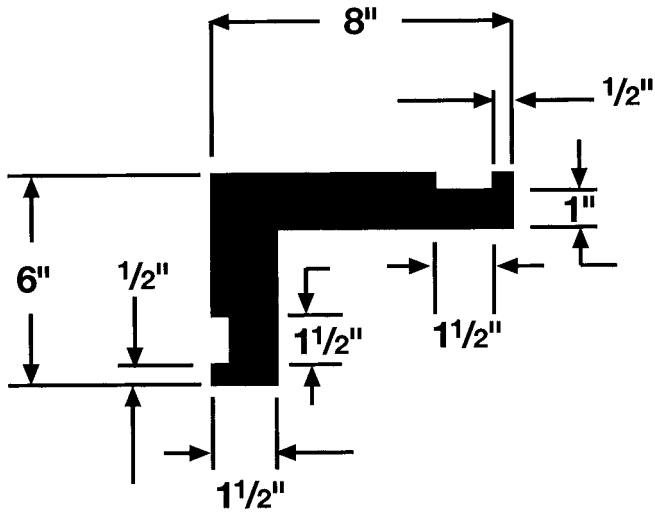

6" x 8" L Section Inside Baffle
Approximate Weight = 9.11 lbs/ft

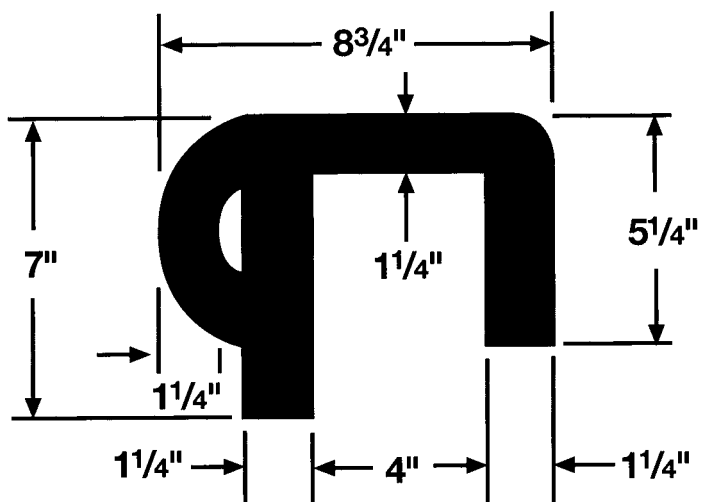

8-3/4" x 7" L Boat Rail Guard
Approximate Weight = 14.00 lbs/ft

DOUBLE BORE SHIP FENDER



(MINIMUM BOW/STERN RADIUS = 36" (915 MM))

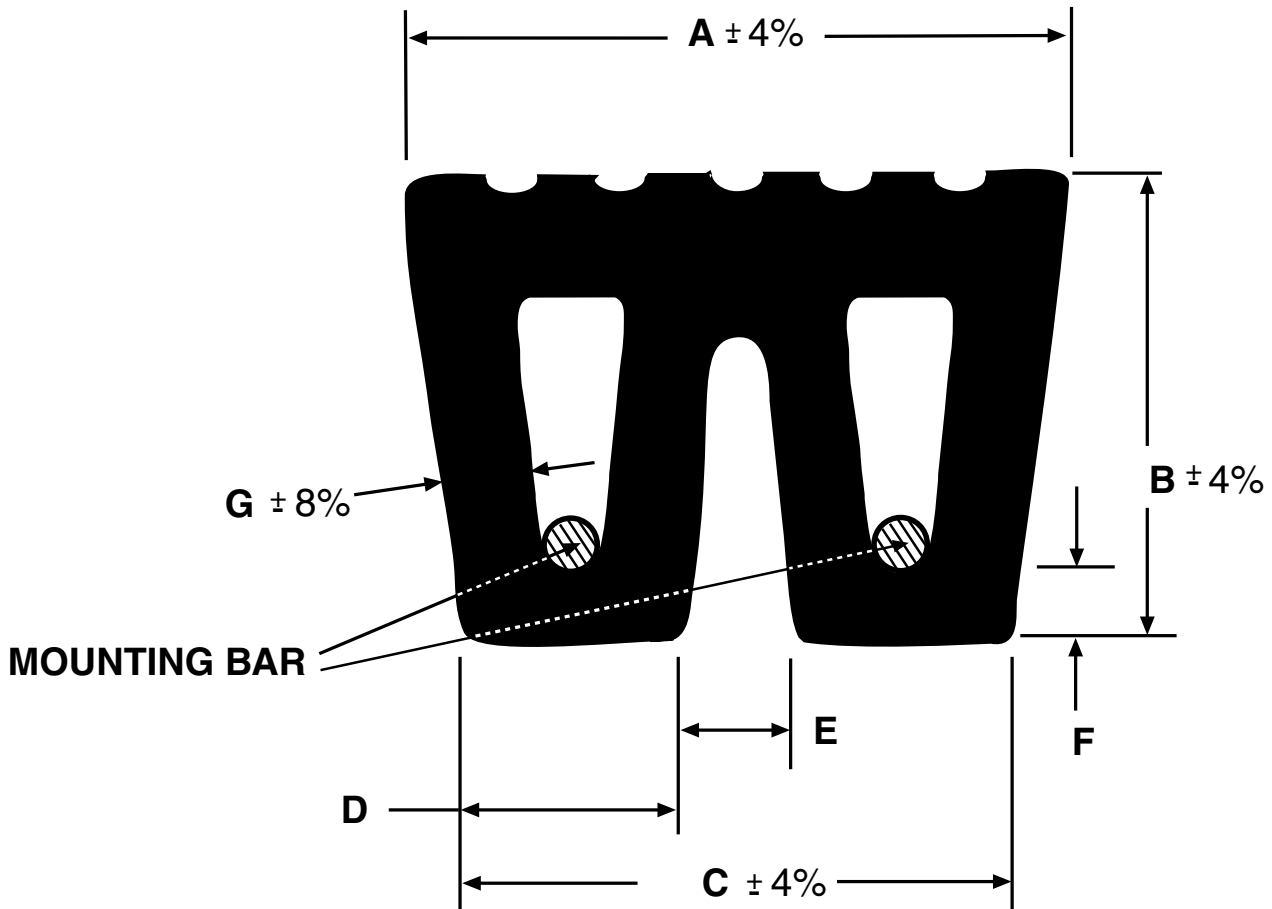

MOUNTING BAR

A		B		C		D		E		F		G		MOUNTING BAR DIA.	
IN	MM	IN	MM	IN	MM	IN	MM	IN	MM	IN	MM	IN	MM	IN	MM
19-11/16	500	14-11/64	373	16-7/32	412	6-29/64	164	3-5/16	84	2-1/8	54	2-9/16	65	1-1/2	38

• NOTE - ADDITIONAL SIZES MAY BE ADDED.

TYPICAL Y.T.B. FENDER SERIES

(Information per Dept. of Navy DWG No. 600-4442434)

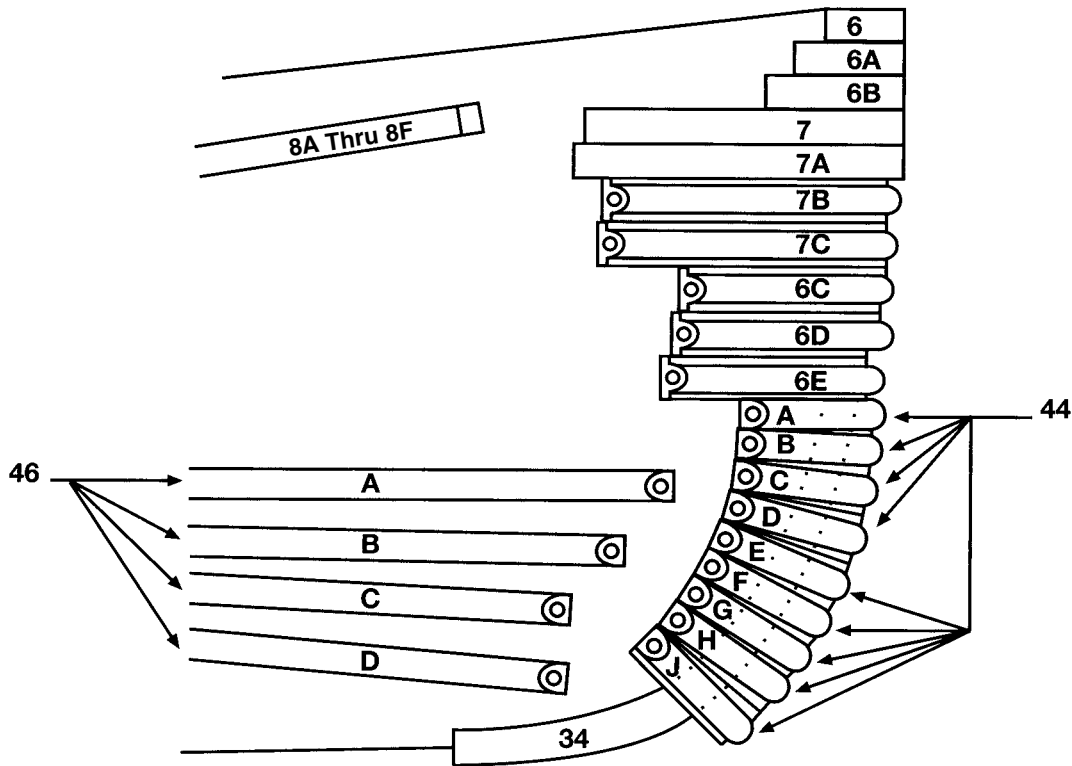

ITEM NO	QTY. REG.	DESCRIPTION	ITEM NO	QTY. REG.	DESCRIPTION
46A	8	D Fender 6" X 19'-4 1/2"LG	8F	2	R Fender 10" x 10" x 4" Bore x 20'-0"LG
46B	8	D Fender 6" X 19'-0"LG	8E	2	R Fender 10" x 10" x 4" Bore x 17'-6"LG
46C	8	D Fender 6" X 17'-0"LG	8D	2	R Fender 10" x 10" x 4" Bore x 17'-6"LG
46D	2	D Fender 6" X 20'-0"LG	8C	2	R Fender 10" x 10" x 4" Bore x 17'-6"LG
44J	1	R Wing Fender Precured & Skived 10" OD x 4" ID x 1'4" Base x 9'-0"LG	8B	2	R Fender 10" x 10" x 4" Bore x 17'-6"LG
44H	1	R Wing Fender Precured & Skived 10" OD x 4" ID x 1'4" Base x 9'-0"LG	8A	2	R Fender 10" x 10" x 4" Bore x 17'-6"LG
44G	1	R Wing Fender Precured & Skived 10"OD x 4"ID x 1'4"Base x 9'-0"LG	7C	1	R Wing Fender 10" x 1'4" x 4" Bore x 20'-0"LG
44F	1	R Wing Fender Precured & Skived 10"OD x 4"ID x 1'4"Base x 9'-0"LG	7B	1	R Wing Fender 10" x 1'4" x 4" Bore x 20'-0"LG
44E	1	R Wing Fender Precured & Skived 10"OD x 4"ID x 1'4"Base x 9'-0"LG	7A	1	R Fender 1'-0" x 1'-0" x 4" Bore x 20'-0"LG
44D	1	R Wing Fender Precured & Skived 10"OD x 4"ID x 1'4"Base x 9'-0"LG	7	1	R Fender 1'-0" x 1'-0" x 4" Bore x 20'-0"LG
44C	1	R Wing Fender Precured & Skived 10"OD x 4"ID x 1'4"Base x 9'-0"LG	6E	1	R Fender 10" x 1'-4" x 4" Bore x 12'-0"LG
44B	1	R Wing Fender Precured & Skived 10"OD x 4"ID x 1'4"Base x 9'-0"LG	6D	1	R Fender 10" x 1'-4" x 4" Bore x 12'-0"LG
44A	1	R Wing Fender Precured & Skived 10"OD x 4"ID x 1'4"Base x 9'-0"LG	6C	1	R Fender 10" x 1'-4" x 4" Bore x 12'-0"LG
			6B	1	R Fender 1'-0" x 1'-0" x 4" Bore x 12'-0"LG
			6A	1	R Fender 1'-0" x 1'-0" x 4" Bore x 10'-4"LG
34	1	R Fender Precured (Split) 1'-6"OD x 9"ID x 18'-6"LG	6	1	R Fender 1'-0" x 1'-0" x 4" Bore x 7'-8"LG

TYPICAL DOCK FENDER INSTALLATIONS



13W Trapezoidal
Northeast Terminal Pier, New York, NY



Precurved
Bow Fender



16V Series Dumbarton Bridge
San Francisco, CA



13 R Trapezoidal
Port of Milwaukee, Milwaukee, WI



1901 LONGWOOD DRIVE - BRENHAM, TX 77833

TELEPHONE: 1-800-888-9703, EXT. 130